



2013

When the Human Factor is at the Core of the Safety Barrier

Maria Chiara Leva

Technological University Dublin, 451611@dit.ie

Catalina Bermudez Angel

Trinity College Dublin

Emmanuel Plot

INERIS

Marco Gattuso

D'Applonia Engineering

Follow this and additional works at: <https://arrow.dit.ie/schfsehart>



Part of the [Business Administration, Management, and Operations Commons](#)

Recommended Citation

Leva, M.C., Angel, C., Plot, E., & Gattuso, M. (2013). When the human factor is at the core of the safety barrier. *CET:Chemical Engineering Transactions*,vol.33, pp.439-444. doi:10.3303/CET1333074.

This Article is brought to you for free and open access by the School of Food Science and Environmental Health at ARROW@TU Dublin. It has been accepted for inclusion in Articles by an authorized administrator of ARROW@TU Dublin. For more information, please contact yvonne.desmond@dit.ie, arrow.admin@dit.ie, brian.widdis@dit.ie.



This work is licensed under a [Creative Commons Attribution-NonCommercial-Share Alike 3.0 License](#)



When the Human Factor Is at the Core of the Safety Barrier

Maria Chiara Leva^{*,a}, Catalina Bermudez Angel^a, Emmanuel Plot^b,
Marco Gattuso^c

^a APRG School of Psychology Trinity College Dublin College Green Dublin 2 Ireland

^b INERIS Parc Technologique ALATA 60550 Verneuil-en-Halatte France

^c D'Applonia Engineering Via Farabola Est, 32 55049 Viareggio (Lucca) Italy

levac@tcd.ie

There are situations in the industry where the human actions are the main safety barriers to abnormal or accidental conditions. In order to maximize the reliability of good human and organizational barriers we need to ensure that the action-plans generated are based on a valid risk assessment of the situation to be addressed and informed by a relevant human factor analysis. This implies that the process needs to be participatory in nature, thus involving end user all the way through. In this paper we present a study in which a critical scenario of vessel overpressure was analyzed using a bowtie. The Bowtie was based on the information provided by a company that supplies industrial gases and services to various industries. The case study is the human and organizational factors that may cause truck drivers to overfill storage tanks on customer premises; the goal is to list proposals for improvement. It became clear that the only safety barrier currently available to avoid the risk of overfilling and possible consequent vessel overpressure is represented by the driver performance on the task. For the example proposed we involved the end user in reviewing the risk assessment and in suggesting possible improvements. The one to be selected were rated on the basis of their impact (in terms of risk reduction) and the difficulty/cost of implementation. The benefit of the approach impacts not only on the quality of the background information provided for the risk assessment but more importantly the involvement of the main end users of the system in assessing their own work performance and being proactively called to identify ways of improving the reliability and safety of it

1. Introduction: Bowties and human factors in risk assessment

1.1 What is a risk assessment and what is its scope

Risk assessment is the logical approach to reviewing hazards in specific scenarios and identifying consequences. This process involves asking three key questions: "What can go wrong?"; "How likely is it that this will happen?"; "If it does happen, what are the consequences?". Risk assessment is often described as a process consisting of three distinct phases: hazard and risk identification, risk estimation and risk evaluation. When risk assessment is implemented correctly it should enable risk assessors to generate 'well founded' risk evaluation (Perry P. 2003). Furthermore it minimizes both the costs to producers and inconveniences to consumers empowering producers, industries and other businesses to demonstrate that they take sufficient efforts to guarantee the safety of their employees and their products.

1.2 What is a Bowtie and how is it used in risk assessment

Accident probability estimation is a common and central step to all risk assessment methods. Among many techniques available, Bowtie model (BT) is very popular because it takes into consideration qualitative and quantitative aspects of a specific scenario (Ferdous R. et al 2013). Bowtie is a risk evaluation method, investigating causes and consequences centred around a critical event. A Bowtie diagram comprises five basic elements: 'Causes' fundamental reasons that result in failures, malfunctions, faults, or human error at a component level. These reasons are termed basic events (BE). 'Fault tree (FT)' graphically represents the path of causation leading to an undesired event. The undesired event is the top event and the interactions of different causes are described using basic events, intermediate events and logic gates.

'Critical event (CE)' in a Bowtie diagram, the top-event of a FT is the initiating event for an ET. This event is called a critical event in the Bowtie. 'Event tree (ET)' sequences the possible consequences of the CE considering a dichotomous barrier (i.e., success/ failure, true/false,) of safety function (e.g., automatic shutdown) or accident escalation factor (e.g., ignition, explosion, and dispersion). 'Outcome events (OE)' are the final consequences resulting from systematic propagation of a CE through the barriers. The safety barriers are located between sequence links, knowing these links allows the definition of the barriers that are to be implemented in order to reduce the occurrence or the gravity of a risk represented by the critical event.

Safety Function: is a technical or procedural action, and not an object or a physical system. It is an action to be achieved in order to avoid or prevent an event or to control or to limit the occurrence of the event. This action will be realised thanks to a safety barrier. The safety function is the "what" needed to assure, increase and/or promote safety.

Safety barrier: a safety barrier can be physical and engineered systems or human actions based on specific procedures or administrative controls. The safety barrier directly serves the safety function. The safety barriers are the "how" to implement safety functions.

Effectiveness: is the ability of a safety barrier to perform a safety function for a duration, in a non-degraded mode and in specified conditions. The effectiveness is either a percentage or a probability of the performance of the defined safety function. If the effectiveness is expressed as a percentage, it may vary during the operating time of the safety barrier.

Level of confidence: is the probability of failure on demand to perform properly a required safety function according to a given effectiveness and response time under all the stated conditions.

2. The importance to consider Human factors in Bowties

The need to incorporate human factors in risk assessment, has been extensively commented in the literature (Taylor 2013, Targoutzidis, 2008). Human factors are understood as the branch of science and technology, which includes what is known and theorized about human behavioural and biological characteristics. It can be applied effectively to the specification, design, evaluation, operation and maintenance of products and systems. Defining and modelling safety barriers is important when analysing the influence of human and organisational factors. Safety barriers are planned to prevent, control or mitigate undesired events or accidents. Undesired events can include technical failures, human errors, external events or a combination of these occurrences that may realise potential hazards. Barrier systems may be classified as passive or active, and as physical, technical or human/operational barriers.

3. How to consider Human factors in Bowties: Example of applications

A proper acquisition of relevant information about a system and a task in a safety critical environment is the foundation of every sound Human Factor analysis. The scope of the analysis may cover a Human Reliability Assessment, an evaluation of a Human-Machine system as a whole, the writing of a procedure or the preparation of a training programme. When this foundation is correctly set, the conclusions of the analysis will be already addressed towards a useful and reliable direction.

More and more studies have highlighted that this critical first step of the analysis has been taken for granted and not given the attention required for collecting and structuring the information about the tasks and contexts. Task analysis is the process of gathering data about the tasks people performs, acquiring a deep understanding of it and representing it. Traditionally the main steps for achieving a task analysis relevant also in the context of a bowtie are:

- a) Preliminary data collection about the task to be modelled (especially if this is a safety barrier).
- b) Update collected data through interviews or observations about the actual way the task is performed
- c) Representation of the information collected
- d) Evaluation of task reliability (i.e., what is the reliability of a task if it is to be considered a safety barrier and what are the performance shaping factors influencing it, which includes an evaluation of the task demands against the operators' capabilities or an evaluation of specific safety issues related to it).

3.1 Accidental scenario: Overfilling of storage tanks on customer locations

The Bowtie selected for the example is the one based on the information provided by a company that supplies industrial gases and services to various industries. The case study is about identifying the human and organizational factors that may cause truck drivers to overfill storage tanks on customer premises; the goal is to identify possible improvements. It became clear that the only safety barrier currently available to avoid the risk of overfilling and possible consequent vessel overpressure is represented by the driver performance on the task (human barrier).

The barrier relies on the fact that the operator opens the overfill valve and that he/she is attentive to spot when liquid phase is coming out of the overfill valve in order to stop the pump on time. The driver needs to:

- ✓ open the overfill valve at the right time;
- ✓ Check to verify it's not blocked;
- ✓ Stop the pump when the liquid phase comes out of the overfill valve; or stop the pump when vessel filled at desired level (taking into account filling and operating pressure);
- ✓ Perform a continuous check of the feasibility of performing safely the tasks (in particular: detection and recovery from equipment failure);
- ✓ Stop loading if it is not feasible.

The risk assessment consisted of a simple Bowtie aimed at analysing the scenario of vessel overfilling.

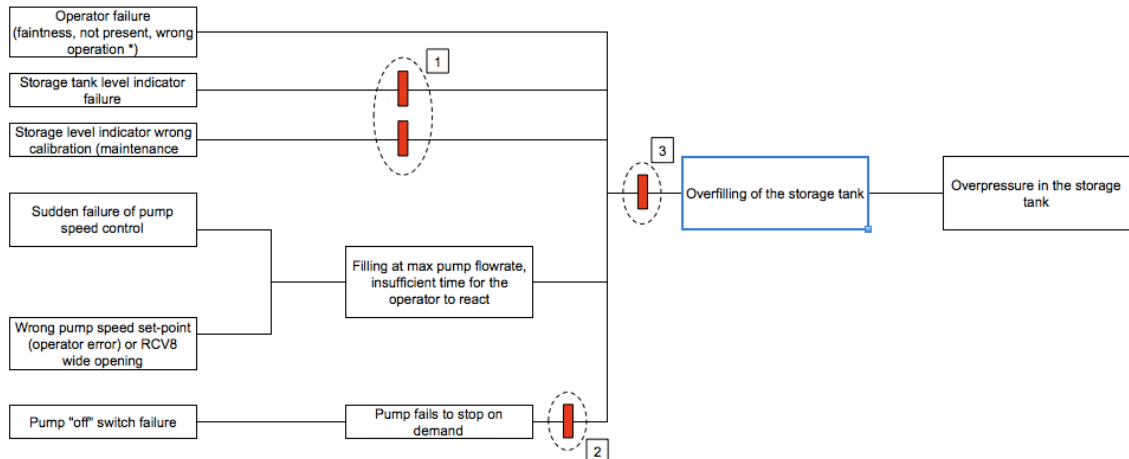

Figure 1; Example of bow tie used for the scenario leading to overfilling of a storage tank where all the preventive barriers are constituted by human tasks

In this framework the problem to be solved was the evaluation of the level of confidence of a safety barrier constituted by an operator task, where the barrier appear to be the only preventive barrier against a critical event of over-pressurization of a vessel. The task analysis used in this context was interlinked with the safety barrier analysis performed around the loading procedure concentrating on the scenarios leading to the risk of overpressurization. The scope was identifying all the possible critical steps and possible deviations in the procedure performed by the drivers everyday to load vessels of different size and operating pressures across different sites in Europe. Further the causes and the relevant performance shaping factors related to those deviations were identified and a qualitative assessment of the likelihood and severity of the resulting scenarios was also performed. This enabled to prioritize areas of interventions and to provide the ground for a preliminary assessment of possible improvement to be devised. The solutions to be devised and the evaluation of those possible solutions followed a user centered design type of approach. The user were involved in revising the task analysis performed and through the use of focus groups and observations all the issues related to the task were highlighted. Further once a prioritized list of those issues/ performance conditions was agreed the possible solutions identified are also going to be discussed with the users for feedback. This user consultation process needs to include the evaluation of new possible devices and their Human Machine interface as well to support their task or to provide an extra safety barrier as an automatic intervention system.

3.1.1 Human safety barriers “identification”

Safety Function. To prevent the consequences of the initial condition “loading of a client vessel with a loading pressure higher than the design pressure of the vessel” we have identify the following safety function: “stop the pump before or at the very beginning of an overfilling”(see Figure 2).

Safety barrier. The existing human barrier able to realize this safety function consists in the fact the operator will open the overfill valve and be attentive to spot when liquid phase is coming out of the valve so as to stop the pump on time. The driver needs to perform all tasks set out above.

Effectiveness: This barrier is effective at 100 %, since it performs completely the safety function.

Level of confidence: The level of confidence of this human barrier is what we tried to evaluate using THERP (Swain and Guttman 1983) modifying the Human Error Probabilities considering the status of relevant performance shaping factors.

3.1.2 Human safety barriers “evaluation”

The task analysis used in this context was interlinked with the safety barrier analysis performed around the loading procedure concentrating on the scenarios leading to the risk of overfilling and consequent overpressurisation. Therefore it aims identifying the possible critical steps and possible deviations in the driver’s loading-vessels routine. The reliability of the human barrier has been analysed representing it into a simple fault tree and quantifying the basic event using THERP (technique for human error arte prediction (Swain and Guttman, 1983). It is a method for predicting human error probabilities, and to evaluate degradation of a man-machine system likely to be caused by human errors alone, or by operational procedures and plant practices, or by other human characteristics that influence behaviour of the plant operator. The subtask is the first step in this methodology. The subtask analysis models the operator actions by identifying and documenting the critical subtask for each operator action. They are often based on the analysis of emergency response guidelines that are generally symptom-based. Therefore, procedural errors assessed can be based on long or short procedures, consistent with the number of main steps in the emergency response guidelines. The quantification of subtasks is the next step in the THERP methodology. This process is done by mathematical presentation of the subtasks and conversion of all independent and dependent operator steps into human error probabilities. Performance shaping factors (PSFs) are used concurrently to modify the nominal human error probability (i.e., the probability of a given human error when the effects of plant-specific performance shaping factors have not yet been considered). The THERP data bank is used to assign probabilities to each operator action or subtask. In the following formulas it will be shown how to evaluate from the Median ($X_{50\%}$) and the Error Factor (EF) the mean value for the lognormal distribution to be used for assessing the final human error probability (HEP).

Example Value for THERP:

$$\begin{cases} X_{50\%} = e^{\mu_z} = 0,001 \\ EF = \frac{X_{95\%}}{X_{50\%}} = e^{Z_{s,95\%}\sigma_z} = 3 \end{cases} \quad (1)$$

$$\mu_z = -6,9 \rightarrow \sigma_z = \frac{\ln 3}{1,645} = \frac{1,098}{1,645} = 0,668 \quad (2)$$

$$\mu_x = e^{\mu_z + \frac{\sigma_z^2}{2}} = e^{-6,9 + \frac{(0,668)^2}{2}} \quad (3)$$

$$\mu_x = e^{-6,67} = 0,00126 \cong 1,3 * 10^{-3} \quad (4)$$

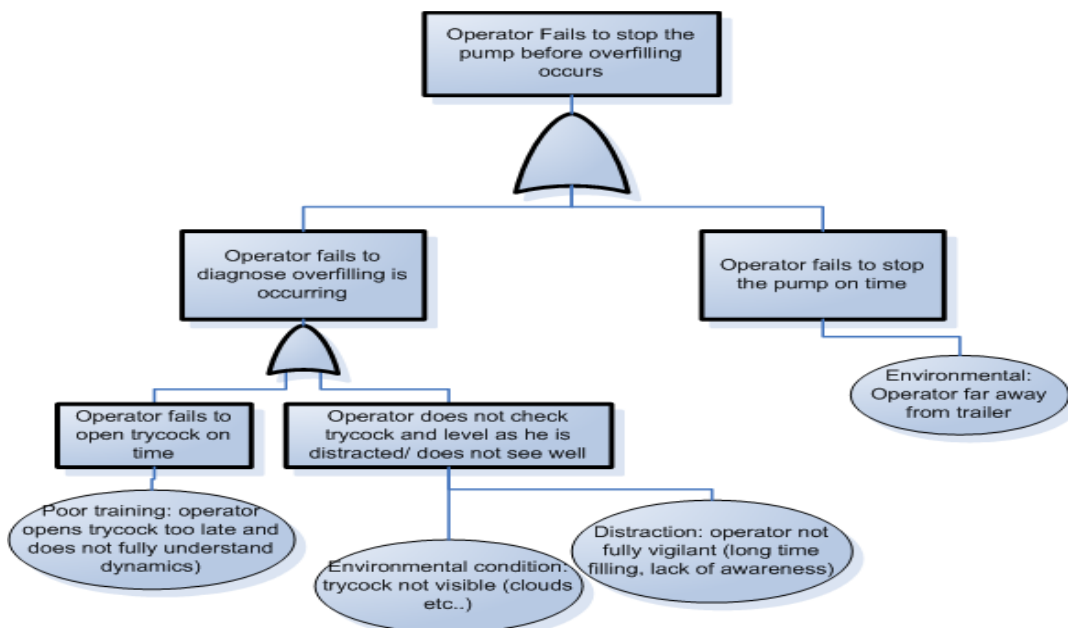

Figure2: Fault tree representing Human safety barrier 1b in the Bowtie of Figure 1

Each mean HEP taken from THERP was also modified by the effects of unfavourable contextual ergonomics conditions. Which are the one mentioned in the oval represented in the Fault tree reported in Figure 2 Table 1 shows an example of assessment for the Human safety barrier reported:

Table 1: Human safety barrier assessed

Item n°	Subtask description for HRA-MAN	Mean HEP	Effects of Performance shaping factors*	Source THERP table	Modified HEP	Total HEP
1	Operator omitted to open overfill valve. (Short List <10)	1.3×10^{-3}	x2	20-7 (3)	2.6×10^{-3}	0.0026
2	Operator does not perform Visual and physical check if the overfill while performing the task	1.3×10^{-3}	x2	20-14 (1)	2.6×10^{-3}	0.0026
3	Operator does not stop the pump on time.	1.2×10^{-3}	x2	20-12 (1)	2.4×10^{-3}	0.0024
TOTAL PROBABILITY OF FAILURE BARRIER 1 Item 1+item 2 +item 3 (failure on demand)						0.0076

4. The role of Influencing factors in the analysis

The varieties of factors affecting the probability of having an overfilling leading to an explosion of the vessel have been grouped in the following five categories:

- 1) Organizational factors: Competence of drivers.
- 2) Technological factors: reliability of equipment and or indications
- 3) Information: background info on vessel, tagging on site,
- 4) External environmental conditions: like the location of the vessel on site (driver may need to be far away from the vessel or have difficulties moving from vessel to trailer, or visibility of overfill valve may not be facilitated).
- 5) Personal factors: fatigue, incapacitation use of PPE (Personal Protective Equipment), lack of motivation, lack of awareness of risks.

Their importance has been rated from 0 (not important at all) to 10 (very important) during the course of two different workshops with the end users. Some examples of Performance shaping factors considered are reported in Figure 3 and Table 2.

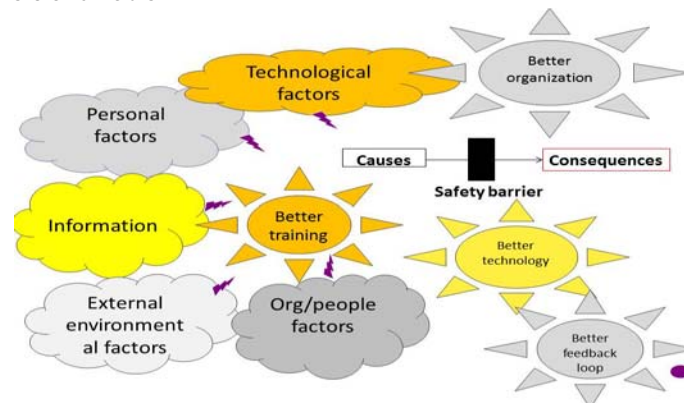

Figure 3: Example of performance shaping factors having an impact on human performance

Table 2: Examples of Performance shaping factors

Antecedents	category	Related barrier	effects on barrier
Level indicator on the vessel not working properly	technology	Stop pump when liquid phase comes out of overfill valve	The operator has to look for liquid phase coming out from overfill valve however the level indicator is often considered and can provide misleading indication delaying intervention

Antecedents	category	Related barrier	effects on barrier
Vessel to be filled remotely through a pipeline not thermally insulated, once filling is completed if operator may leave without purging the pipeline as well (extra task not contemplated in usual procedure)	people competence	As above	Possible residual pressure in the pipeline may bring to a pipeline critical overpressure
Liquid phase coming out from overflow valve may not be clearly visible because of atmospheric conditions (fog, rain etc.)	external environment	As above	The operator may not realize in time when overflowing occurs
Operator may have to wait for a long time during filling and therefore not have enough attention to carry out the task	personal	As above	The operator may not realize in time when overflowing occurs
The operator may forget to open the overflow valve or open it too late	people procedure	As above	The operator may not realize in time if overflowing occurs

5. Current conclusions and way forward

There are situation in the industry where the human actions are the main safety barriers to abnormal or accidental conditions. In order to maximize the reliability of good human and organizational barriers we need to ensure that the action-plans generated are based on a valid risk assessment of the situation to be addressed and informed by a relevant human factor analysis. This implies that the process needs to be participatory in nature, thus involving end user all the way through. For the example proposed we involved the end user also in suggesting possible improvement actions. The one to be selected were rated on the basis of their impact and the difficulty/cost of implementation, the impact was informed by the risk assessment effects on the reliability of the barrier but also by what priority the action was assigned during a focus group with the end users. Example of suggested actions are not reported in the current paper.

The evaluation of this work is based on the:

- coherence between the proposals themselves
- coherence between the proposals and the :
 - a. the bow tie analysis
 - b. The task analysis informing the bowtie and the list of the performance shaping factors selected

The benefit of the approach reflects not only on the quality of the background information provided for the risk assessment but more importantly on the involvement of the main end users of the system in assessing their own work performance and being proactively called to identify way of improving the reliability and safety of it. SO even if a further level of automation is identified as a further safety barrier it will be designed in a way that will keep the user proactively in the loop.

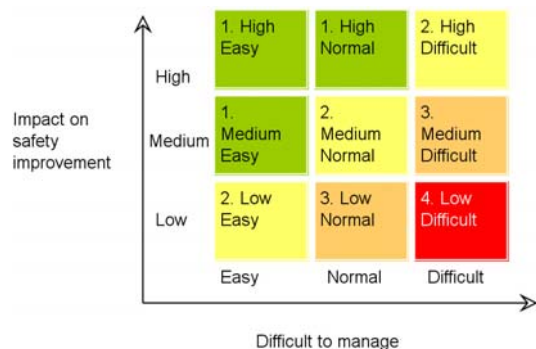

Figure 4: cells box matrix used for feasibility rating of improvements plans

References

Ferdous R., Khan F., Sadiq R., Amyotte P. & Veitch B. (2013). 'Analyzing system safety and risks under uncertainty using a bow-tie diagram: An innovative approach'. Process Safety and Environmental Protection, 91, 1–18.

Perry P. (2003). Risk Assessment, Questions and Answers: a practical approach (1st Ed.). Thomas Telford books Ltd, London

Swain D. and Guttman H.E. (1983) Handbook of Human Reliability Analysis with Emphasis on Nuclear Power Plant Applications, draft, NUREG/CR-1278.

Targoutzidis A. (2009). 'Incorporating human factors into a simplified "bow-tie" approach for workplace risk assessment'. Safety Science, 48, 145–156.

Taylor J.R., (2013). Incorporating Human Error Analysis into Process Plant Safety Analysis CHEMICAL ENGINEERING TRANSACTIONS VOL. 31, 2013 301-306..