



2009-08-12

# Development of a Theoretical Decoupled Stirling Cycle Engine

Barry Cullen

*Technological University Dublin, barry.cullen@dit.ie*

Jim McGovern

*Dublin Institute of Technology, jim.mcgovern@dit.ie*

Follow this and additional works at: <https://arrow.dit.ie/dubencon2>

 Part of the [Energy Systems Commons](#), and the [Other Engineering Commons](#)

## Recommended Citation

Cullen, B., McGovern, J. (2009). Development of a theoretical decoupled stirling cycle engine. *3rd International Conference on Sustainable Energy and Environmental Protection (SEEP)*, Dublin, Ireland, 12-15 August.

This Conference Paper is brought to you for free and open access by the Dublin Energy Lab at ARROW@TU Dublin. It has been accepted for inclusion in Conference Papers by an authorized administrator of ARROW@TU Dublin. For more information, please contact [yvonne.desmond@dit.ie](mailto:yvonne.desmond@dit.ie), [arrow.admin@dit.ie](mailto:arrow.admin@dit.ie), [brian.widdis@dit.ie](mailto:brian.widdis@dit.ie).



This work is licensed under a [Creative Commons Attribution-NonCommercial-Share Alike 3.0 License](#)



## DEVELOPMENT OF A THEORETICAL DECOUPLED STIRLING CYCLE ENGINE

**Barry Cullen and Jim McGovern**

Department of Mechanical Engineering, Dublin Institute of Technology, Bolton Street, Dublin 1 and Dublin Energy Lab, Dublin Institute of Technology  
email: [barry.cullen@dit.ie](mailto:barry.cullen@dit.ie); [jim.mcgovern@dit.ie](mailto:jim.mcgovern@dit.ie)

### ABSTRACT

The Stirling cycle engine is gaining increasing attention in the current energy market as a clean, quiet and versatile prime mover for use in such situations as solar thermal generation, micro cogeneration and other micro distributed generation situations.

A theoretical Stirling cycle engine model is developed. Using a theoretical decoupled engine configuration in which working space swept volume, volume variation, phase angle and dead space ratio are controlled via a black-box electronic controller, a model is developed that is to be used as a tool for analysis of the ideal Stirling cycle engine and the limits on its real world realisation.

The theoretical configuration approximates the five-space configuration common in Stirling cycle analysis. It comprises two working spaces and three heat exchangers: hot side, cold side and the regenerator between. The kinematic crank mechanism is replaced with an electronically controlled motor/generator system, with one motor/generator controlling each of the working pistons. Use of stop valves permits flow and non-flow processes inherent in the ideal cycle to be realised.

The engine configuration considered here is not intended as a viable prime mover but rather a tool for study of the limitations of the cycle.

### 1.0 INTRODUCTION

The Stirling engine is a closed cycle, regenerative, external combustion reciprocating engine that relies for its power conversion on the cyclic heating and cooling of a fixed mass of gas within the engine. At the time of its invention, steam engines were the dominant power generation technology, and although it offered a competitive and, importantly, safer alternative to such engines, it never seriously challenged their market share [1]. Similarly, although it predated the Otto and Diesel cycle engines by some fifty years, it has struggled to maintain market presence in competition with these Internal Combustion engines since their introduction in the late nineteenth century. The reasons for this are numerous but are generally held to stem from its relatively sluggish response characteristics, its low power-to-weight ratio and its comparatively expensive manufacturing requirements [2-5]. However, being an external combustion engine, it does benefit from an omnivorous fuel or heat source capability and quiet operation. It was these characteristics that reinvigorated interest in the engine in the nineteen thirties in the Philips

Electric Company, Eindhoven, and have continued to drive its development in the modern day for applications in distributed generation, particularly solar thermal generation and micro cogeneration applications[6-10].

The practical Stirling cycle always departs significantly from the ideal cycle. There are several reasons for this, corresponding particularly to the performance of the heat exchangers and the regenerator and the achievement of volume variations through the use of crank-and-connecting-rod or other mechanisms. The latter is of relevance in the current work. A decoupled arrangement is proposed that utilises four separate motor/generator units for the achievement of volumetric variations of the working fluid, thereby permitting more complete control over the volume changes in the cycle. This paper presents an initial conceptual treatment of the proposed mechanism and a discussion of its possible merits. The concept is not intended as

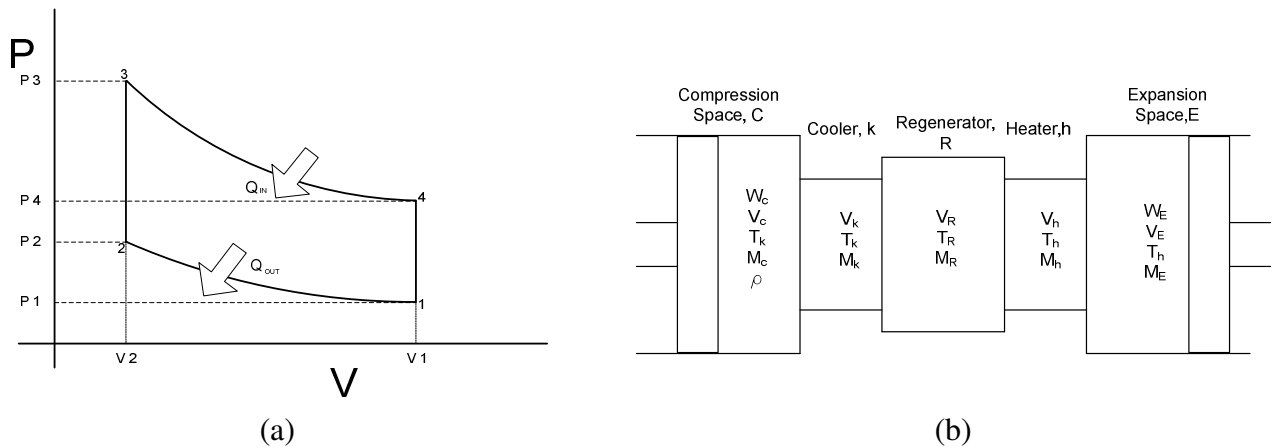

Figure 1. The Stirling cycle (a) air standard cycle (b) five space ideal Stirling engine circuit

a viable prime mover at this preliminary stage but rather a conceptual device useful for consideration of the ideal cycle and its practical realisation.

## 2.0 THE STIRLING CYCLE ENGINE

### 2.1 Ideal Cycle

Figure 1 (a) shows the ideal Stirling thermodynamic cycle. The air standard cycle comprises the following four processes [5, 11]:

1-2: Isothermal compression: heat rejection to external sink

2-3: Isochoric regeneration: internal heat transfer from the working fluid to the regenerator

3-4: Isothermal expansion: heat addition from external source

4-1: Isochoric regeneration: internal heat transfer from the regenerator to the working fluid

The realisation of this cycle is usually described in terms of a 5-space configuration, as seen in Fig. 1(b) [4, 12]. The expansion and compression working spaces are complemented by three heat exchange devices: a hot side heat exchanger, which admits heat to the system; a cold side heat exchanger which rejects heat from the system; and a regenerator linking the two heat exchangers.

### 2.2 Stirling Engines – State of the Art and Limitations

The modern Stirling engine is a versatile and technologically developed device. The engines can broadly be divided according to their

attributes into Kinematic or Free Piston machines. Kinematic engines use kinematic drive mechanisms to regulate the volume variations in the working spaces. Free Piston machines use gas pressure variations in the cycle to control the movement of the displacer piston [13-15]. These engines were pioneered in the 1960's by William Beale and offer their own set of advantages, particularly in relation to reduction of friction losses in the drive. They find use in solar thermal plant and in remote generation in space [8, 16]. Kinematic engines are of interest in the present work, however. A number of variations exist on the kinematic mechanisms used in the Stirling engine. The traditional modelling of the cycle, as first offered by Schmidt, treats the volume variations as being harmonic sinusoidal [4]. This is a significant departure from the ideal case and has the effect of reducing the cycle work. Narasimhan and Adinarayan present an evaluation of the displacement-time characteristics of various Stirling engine drive mechanisms in terms of optimum specific work of the engine [17, 18]. Crank/connecting rod, Crank/connecting rod/cross head, Ross yoke, wobble yoke and rhombic drive are all examples of kinematic mechanisms previously deployed [5, 12]. Such mechanical mechanisms offer a harmonic or near harmonic variation in system working volumes. Fang et al describe an elliptical drive that more closely approximates the ideal non harmonic volume variations [19].

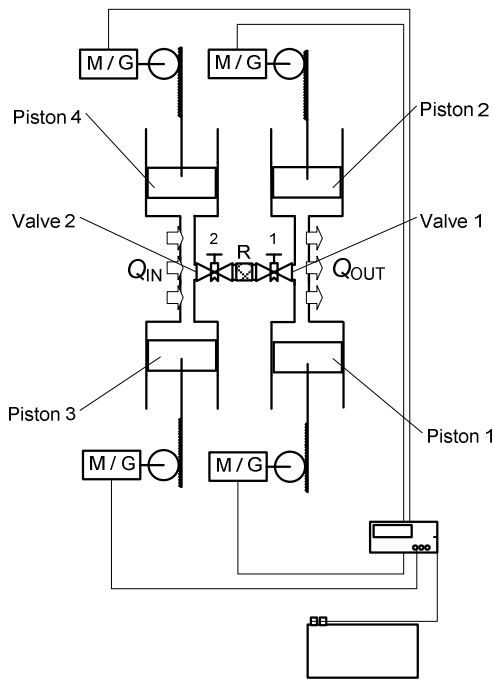

Figure 2. Decoupled Stirling engine configuration

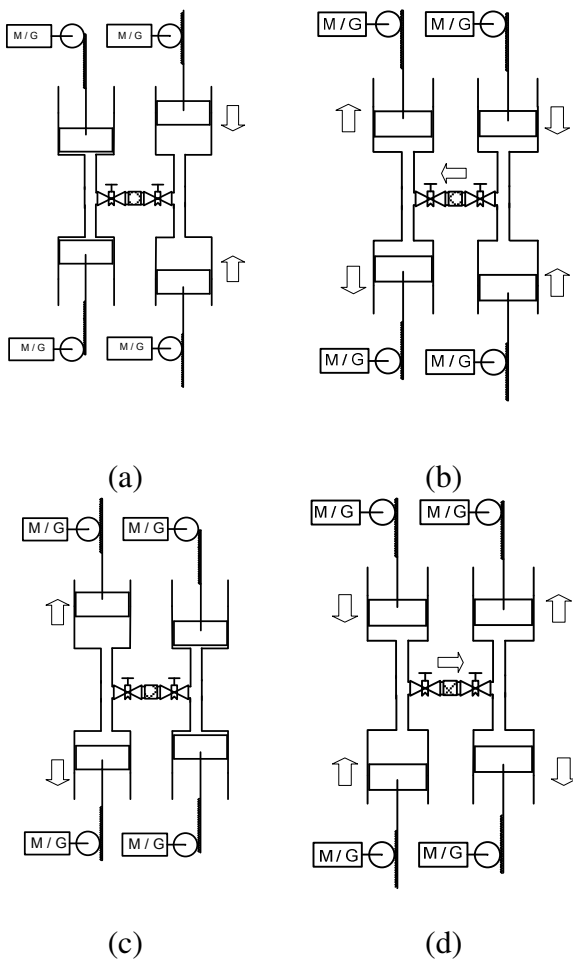

Figure 3. Execution of Stirling cycle using decoupled engine configuration (a) isothermal compression (b) constant volume regenerative heat exchange (c) isothermal expansion (d) constant volume regenerative heat exchange

### 3.0 PROPOSED ENGINE CONFIGURATION

Figure 2 shows the proposed engine configuration for the present work. The two working spaces (heated/expansion space and cooled/compression space) are shown as operating with two pistons each. The working spaces are isolated from each other through the use of cut-off valves 1 and 2 in the line on either side of the regenerator, R. The pistons are each actuated by a motor/generator via a rack and pinion gear and are controlled by a black-box electronic controller. Power storage is represented in the diagram as being from a battery, although grid connection is also feasible. As the realisation of the thermodynamic circuit is the issue of concern for this study, technical considerations relating to the electronic control and power storage are not elaborated on.

### 4.0 THERMODYNAMIC ANALYSIS

#### 4.1 Description of Operation

##### Assumptions - Heat Exchange Volumes

Ideally the hot and cold side heat exchangers and the regenerator would have negligible internal volume but very large internal surface area. They would also, ideally, present negligible resistance to the flow of the working gas. These ideals cannot be attained in practice, but the volumes, areas and flow-resistance characteristics are amenable to modeling and engineering optimization.

The regenerator ideally has no internal thermal conductivity that would allow heat transfer through the thermal gradient that it contains (ideally from the source temperature to the sink temperature), but departures from the ideal can be modeled.

Ideally, all volume of the working fluid is contained within the four working spaces that are swept by the four pistons shown in Fig. 2. Ideally, the fluid temperature in each working space is uniform and the working space boundaries are adiabatic. Departures from this could be modeled and quantified.

##### Process 1-2 Sawtooth Approximation of Isothermal Compression

Figure 3 (a) shows how the compression process is achieved by reduction of the total

volume on the cold side. The gas is sealed in the cooled side of the engine, comprising the cooling heat exchanger and the piston swept volume, at pressure  $P_1$  by the closing of valve 1. Pistons 1 and 2 are actuated by the movement of the opposed motor/generators. After the fluid has been compressed a small amount, the temperature of the fluid will have been raised by a small amount. The pistons stop and both pistons move in tandem, transferring the fluid at constant volume through the heat exchanger. The process is repeated in an oscillating pattern until the gas is cooled and compressed to the minimum system volume required. The net effect is an incremental compression with improved fluid flow through the heat exchanger and hence improved heat transfer compared to the simple single-cooling-space moving piston and attached or integral heat exchanger alternative. A P-V diagram is shown in Fig. 4(a) and a displacement-time diagram is shown in Fig.4(b) to demonstrate the compression process. This oscillating approach offers a sawtooth approximation to isothermal heat exchange conditions, as the small temperature rises due to compression are partly negated through the combined movement of the two pistons and the extra heat transfer afforded by the additional passes through the exchanger. In this treatment of the engine pressure losses associated with transfer through the heat exchanger are assumed negligible, although this could be modelled. The final state of the fluid in the compression space is a pressure of  $P_{(1+2n)}$  and temperature of  $T_{(1+2n)}$ .

#### *Process 2-3 Constant Volume Heat Addition (Regeneration)*

Figure 3 (b) shows the first constant volume heat transfer process. When the gas reaches pressure  $P_{(1+2n)}$ , valve 1 opens, allowing fluid flow from the cooling space to the heating space via the regenerator and valve 2. Both compression pistons move to Top Dead Centre (TDC) to fully evacuate the space. Both expansion side pistons move out to facilitate the constant volume flow process. The fluid collects heat from the regenerator upon passing, and enters the expansion chamber at an elevated temperature.

#### *Process 3-4 Sawtooth Approximation of Isothermal Expansion*

Figure 3 (c) shows the isothermal expansion. Valve 2 closes, sealing the gas within the hot side of the engine. Similar to the compression phase, expansion is completed by the combined movement of the two pistons and the incremental increase in volume by the pistons. Again, this movement allows increased fluid mixing and facilitates heat exchange into the system in the hot side heat exchanger.

#### *Process 4-1 Constant Volume Heat Rejection (Regeneration)*

Figure 3 (d) shows the second constant volume heat transfer process. When the gas reaches  $P_{(2+2n+2m)}$ , valve 2 opens allowing fluid flow from the expansion space to the compression space via the regenerator. As before the two pistons move towards TDC to fully evacuate the chamber.

## **4.2 Calculation of Engine Work**

For the ideal air standard Stirling cycle, Fig. 1(a), the Work output of the cycle is calculated as:

$$W_{STIRLING} = [Q_{34} + Q_{12}] \quad (1)$$

$$W_{STIRLING} = R \left\{ T_H \ln \left[ \frac{P_3}{P_4} \right] + T_L \ln \left[ \frac{P_2}{P_1} \right] \right\} \quad (3)$$

For the decoupled engine we must account for the oscillating motion of the twin piston arrangement to facilitate heat exchange.

Figure 4(a) presents the ideal cycle for the decoupled system. We see adiabatic compression processes followed by constant volume heat rejection from the system, as well as adiabatic expansion processes followed by constant volume heat addition to the system. The number of oscillations is not specified, so a generalised thermodynamic analysis is provided. Expansion and compression are assumed to be isentropic, and the ideal gas laws are assumed to apply.

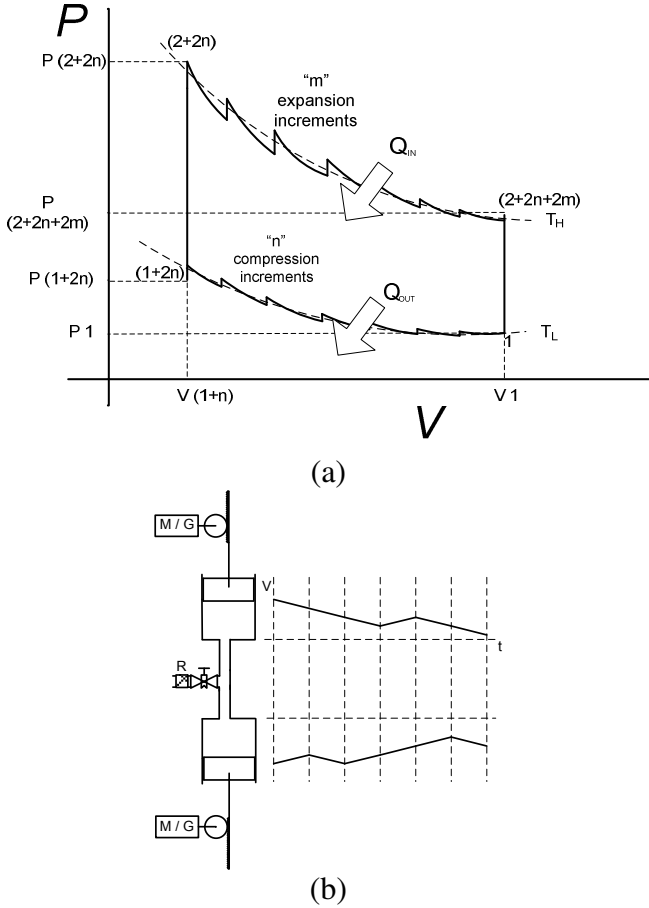

Figure 4. Oscillating decoupled piston cycle (a) P–V indicator diagram (b) Displacement–time diagram of cooling space demonstrating oscillating operation

The number of thermodynamic state points will depend on the number of compression increments,  $n$ , and expansion increments,  $m$ . We see that for each compression increment a heat exchange process follows, so that we can say that there are  $2n$  state points on the compression side and  $2m$  on the expansion side.

#### Process 1: Adiabatic Compression with Constant Volume Heat Rejection

After the Adiabatic compression and expansion processes:

$$P_{i+1} = P_i \left( \frac{V_i}{V_{i+1}} \right)^k \quad (1)$$

$$T_{i+1} = T_i \left( \frac{V_i}{V_{i+1}} \right)^{k-1} \quad (2)$$

Heat rejection at constant volume:

$$q_{R,i} = \varepsilon c_v (T_{i+2} - T_{i+1}) \quad (3)$$

Where:

$$T_{i+2} = T_{i+1} \left( \frac{P_{i+2}}{P_{i+1}} \right) \quad (4)$$

$k$  is the ratio of specific heats,  $c_v$  is the specific heat of the fluid at constant volume and  $\varepsilon$  is the heat exchanger effectiveness and  $T_{i+2}$  is the temperature of the gas after the heat transfer. Therefore, the total heat rejected from the cycle over  $n$  compression increments is the algebraic sum of the heat quantities rejected during each constant volume process:

$$q_{R,TOTAL} = \sum_{i=1}^n q_i \quad (5)$$

Where  $q_i$  is the generalised form of the heat equation offered in eq.(3) and  $n$  is the total number of compression increments.

#### Process 2 and Process 4: Constant Volume Regeneration Processes

Assuming perfect regeneration, no net heat is gained or lost by the system.

#### Process 3: Adiabatic Expansion with Constant Volume Heat Addition

Similar to Process 1, the expansion of the gas is achieved incrementally through a series of adiabatic expansion processes followed by constant volume heat addition processes. The number of oscillations is controlled by the black box controller which actuates the motor/generators at the desired frequency. Consider point (1+2n) as in Fig. 4(a) above. After the Adiabatic expansion process:

$$P_{2+2n} = P_{1+2n} \left( \frac{V_{1+2n}}{V_{2+2n}} \right)^k \quad (6)$$

$$T_{2+2n} = T_{1+2n} \left( \frac{V_{1+2n}}{V_{2+2n}} \right)^{k-1} \quad (7)$$

The heat addition process occurs at constant volume after the adiabatic expansion process. Heat added at constant volume, per unit mass:

$$q_A = \varepsilon c_v (T_{3+2n} - T_{2+2n}) \quad (8)$$

Where:

$$T_{3+2n} = T_{2+2n} \left( \frac{P_{3+2n}}{P_{2+2n}} \right) \quad (9)$$

And  $c_v$  is the specific heat of the gas at constant volume. Therefore, the total heat admitted to the cycle is the algebraic sum of the heat quantities added during each constant volume process:

$$q_{A,TOTAL} = \sum_{i=(2+2n)}^m q_i \quad (10)$$

Where  $q_i$  is the generalised form of the heat equation as before. The work done by the system is therefore:

$$W_{STIRLING} = q_{A,TOTAL} + q_{R,TOTAL} \quad (11)$$

### 4.3 Calculation of Engine Efficiency

The efficiency of the engine can be expressed as:

$$\eta = \frac{W_{STIRLING}}{q_{A,TOTAL}} \quad (14)$$

Therefore:

$$\eta = \frac{q_{A,TOTAL} + q_{R,TOTAL}}{q_{A,TOTAL}} \quad (15)$$

### 5.0 PHASE ANGLE AND DEAD SPACE RATIO CONTROL

The use of the motor/generators and their electronic control yield another advantage. The control offered by the decoupling of the system in the manner proposed implies the ability to manipulate such system parameters as working space swept volumes, system dead volume and the phase angle. Dead volume is defined as the total volume in the system that remains unswept by a piston and phase angle is the angle by which volume variations in the expansion cylinder lead those in the

compression cylinder [20]. The apparatus described above could therefore easily allow optimisation of the phase angle and dead volume ratios for given swept volumes.

### 6.0 CONCLUSIONS AND COMMENTS

A kinematically decoupled Stirling cycle engine has been described. A major source of departure of the practical Stirling cycle from the ideal cycle is the sinusoidal volume variations experienced in the working spaces. These variations are controlled by the crank/connecting rod or by a similar drive mechanism. Although some efforts have been made in the past to more closely resemble the constant volume processes through the use of various drive configurations, none have succeeded in the exact duplication of the ideal conditions. Instead of a crank connected system, the working volume variations in the proposed engine are controlled through electronically controlled motor/generators connected to the pistons via rack and pinion gearing, although any linear actuator could be used. It is proposed that the higher degree of control afforded by the inclusion of the electronic controller would permit volume variations that more closely correspond to those in the ideal cycle.

A second major departure from the ideal cycle occurs through the non isothermal heat transfer to and from the system. True isothermal conditions would require an infinitely slow transfer process, ie an infinitely slow engine, or infinite heat transfer, neither of which can be realised in a practical engine. An approximation to the isothermal condition is proposed in this work whereby the compression and expansion processes are completed in an oscillating manner between two pistons, allowing a more complete mixing of the gas in the heat exchangers. This would allow greater heat transfer through processes that resemble inter-cooling and reheating as might be seen on certain turbo-machinery

### REFERENCES

1. Hargreaves, C.M., *The Philips Stirling Engine*. 1991, Amsterdam: Elsevier Science Publishers B.V.
2. Cullen, Barry and Jim McGovern. *The Stirling Engine as a Prime Mover*. in

- European Symposium on Applied Thermodynamics*. 2008. Cannes, France: Institut National Polytechnique de Lorraine.
3. Finkelstein, Theodor and Allan J. Organ, *Air Engines*. 2001: Professional Engineering Publishing Ltd.
  4. Organ, Allan J., *Thermodynamics and Gas Dynamics of the Stirling Cycle Machine*. 1992: Cambridge University Press.
  5. Walker, Graham, et al., *The Stirling Alternative*. 1994: Gordon and Breach Science Publishers.
  6. Kongtragool, Bancha and Somchai Wongwises, *A review of solar-powered Stirling engines and low temperature differential Stirling engines*. *Renewable and Sustainable Energy Reviews*, 2003. **7**(2): p. 131-154.
  7. De Paepe, Michel, Peter D'Herdt, and David Mertens, *Micro-CHP systems for residential applications*. *Energy Conversion and Management*, 2006. **47**(18-19): p. 3435-3446.
  8. Brandhorst Jr, Henry W. and Peter A. Chapman Jr, *New 5 kW free-piston Stirling space convertor developments*. *Acta Astronautica*, 2008. **63**(1-4): p. 342-347.
  9. Costea, M., S. Petrescu, and C. Harman, *The effect of irreversibilities on solar Stirling engine cycle performance*. *Energy Conversion and Management*, 1999. **40**(15-16): p. 1723-1731.
  10. Kelly, N. J., et al., *Developing and testing a generic micro-combined heat and power model for simulations of dwellings and highly distributed power systems*. *Proceedings of the Institution of Mechanical Engineers, Part A: Journal of Power and Energy*, 2008. **222**(7): p. 685-695.
  11. Cengel, Yunus A. and Michael A. Boles, *Thermodynamics An Engineering Approach*. Fourth Edition ed. 2002: McGraw Hill.
  12. Urieli, Israel and David M. Berchowitz, *Stirling Cycle Engine Analysis*. 1984, Bristol: Hilger.
  13. Rogdakis, E. D., N. A. Bormpilas, and I. K. Koniakos, *A thermodynamic study for the optimization of stable operation of free piston Stirling engines*. *Energy Conversion and Management*, 2004. **45**(4): p. 575-593.
  14. Boucher, J., F. Lanzetta, and P. Nika, *Optimization of a dual free piston Stirling engine*. *Applied Thermal Engineering*, 2007. **27**(4): p. 802-811.
  15. Thombare, D.G. and S.K. Verma, *Technological Development in the Stirling Cycle Engines*. *Renewable and Sustainable Energy Reviews*, 2006(doi:10.1016/j.rser.2006.07.001).
  16. *Infinia on the Sun*. 2007 [cited; Available from: [http://www.infiniacorp.com/application/clean\\_energy.php](http://www.infiniacorp.com/application/clean_energy.php).
  17. Narasimhan, M. V. and T. V. Adinarayan. *Evaluation of displacement - time characteristics of stirling engine drive mechanisms - I*. in *Energy Conversion Engineering Conference, 1990. IECEC-90. Proceedings of the 25th Intersociety*. 1990.
  18. Narasimhan, M. V. and T. V. Adinarayan. *Evaluation of displacement - time characteristics of stirling engine drive mechanisms - II*. in *Energy Conversion Engineering Conference, 1990. IECEC-90. Proceedings of the 25th Intersociety*. 1990.
  19. Fang, H. W., et al. *A novel Stirling engine with an elliptic drive*. in *Energy Conversion Engineering Conference, 1996. IECEC 96. Proceedings of the 31st Intersociety*. 1996.
  20. Walker, Graham, *Stirling Engines*. 1980, Oxford: Clarendon Press.