



2006-01-01

Experimental Comparison of Wired Versus Wireless Video Streaming over IEEE 802.11b WLANs

Tanmoy Debnath

Dublin Institute of Technology, Tanmoy.Debnath@dit.ie

Nicola Cranley

Dublin Institute of Technology, nicola.cranley@dit.ie

Mark Davis

Dublin Institute of Technology, mark.davis@dit.ie

Follow this and additional works at: <http://arrow.dit.ie/commcon>

 Part of the [Electrical and Electronics Commons](#)

Recommended Citation

Debnath, T., Cranley, N. & Davis, M. (2006) Experimental Comparison of Wired Versus Wireless Video Streaming over IEEE 802.11b WLANs. *Irish Signals and Systems Conference ISSC 2006*. Pages: 235-240. ISBN: 0863416659. DOI: 10.1049/cp:20060443.

This Conference Paper is brought to you for free and open access by the Communications Network Research Institute at ARROW@DIT. It has been accepted for inclusion in Conference papers by an authorized administrator of ARROW@DIT. For more information, please contact yvonne.desmond@dit.ie, arrow.admin@dit.ie, brian.widdis@dit.ie.



This work is licensed under a [Creative Commons Attribution-NonCommercial-Share Alike 3.0 License](#)



Experimental Comparison of Wired versus Wireless Video Streaming over IEEE 802.11b WLANs

Tanmoy Debnath, Nicola Cranley, Mark Davis

*Communications Network Research Institute,
School of Electronic and Communications Engineering,
Dublin Institute of Technology,
Dublin 8, Ireland*

tanmoy.debnath@cnri.dit.ie, nikki.cranley@cnri.dit.ie, mark.davis@dit.ie

Abstract

In this paper the performance of streaming MPEG-4 video with a video server located on the wired network streaming to wireless clients is compared with the performance of a video server located in the wireless network streaming to wireless video clients. We experimentally investigate the performance for a number of concurrent video streams with varying video frame sizes, frame rates and packetisation schemes. The performance is measured in terms of the key parameters of bit rate, loss rate and mean delay. We show how that there is a trade-off for these parameters for a wired and wireless located server. We show that a wired located server is susceptible to high loss rates when there are a number of concurrent video streams whilst the wireless located server has greater reliability in terms of loss rate but incurs greater delays due to having to compete to access to the medium.

Keywords – IEEE 802.11, WLAN, Video Streaming.

I INTRODUCTION

Streaming multimedia over wireless networks is becoming an increasingly important service. This trend includes the deployment of WLANs that enable users to access various services including those that distribute rich media content anywhere, anytime and from any device. There are many performance-related issues associated with the delivery of time-sensitive multimedia content using current IEEE 802.11 standards. Among the most significant are low delivery rates, high error rates due to media characteristics, contention between stations for access to the medium, back-off mechanisms, collisions, signal attenuation with distance, signal interference, etc. Multimedia applications, in particular, impose onerous resource requirements on bandwidth constrained WLAN networks [1,2]. The bursty nature of video streaming applications is due to the frame-based structure of video and this affects the ability of the WLAN network to provide Quality of Service (QoS), particularly under heavily loaded conditions since the capacity of the network varies over time. [3].

A large and diverse number of variables are needed to be considered when analysing multimedia

streaming such as the encoding configuration which includes the bit rate, complexity of the content, the compression scheme, the frame rate, frame size, the packetisation scheme used to transmit video, and the streaming server being used.

In this paper we analyze the performance of video streaming applications in terms of bitrate fluctuations, packet loss and loss due to excessive delay since these are the primary factors that affect the perceived video quality at the receiver. We show how these parameters vary when using a wired and wireless video streaming server. Furthermore, we show that as the number of parallel streams increases, the QoS of the video streaming application is reduced. Our experimental results demonstrate that a trade-off exists for wired and wireless streaming in terms of received bitrate, loss rate and delay.

The paper is structured as follows. Section 2 describes the experimental setup, Section 3 presents the experimental results and analysis. Finally Section 4 presents conclusions and directions for future work.

II EXPERIMENTAL TEST BED

In this work two video streaming configurations for streaming MPEG-4 video are investigated as shown in Figure 1. The first is when the video server

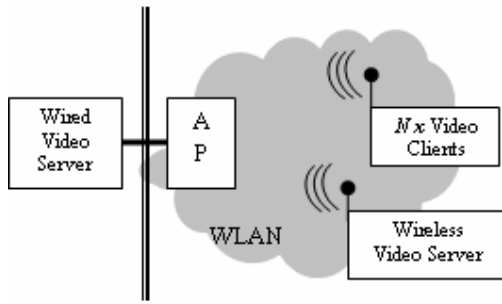

Fig.1. Experimental Test Bed

is located on the wired network and is streaming video via the Access Point (AP) to a wireless client. The second case is when the video server is located on the WLAN and is streaming video wireless via the AP to a wireless client. Both the client and server were configured with the packet monitoring tool, WinDump [4] and the clocks of both the client and server are synchronised before each test using NetTime [5]. However, in spite of clock synchronisation, there was a noticeable clock skew observed in the delay measurements and this was subsequently removed using Paxson's algorithm as described in [6]. The delay is measured here as the difference between the time at which the packet was received at link-layer of the client and the time it was transmitted at the link-layer of the sender.

Given the large number of encoding parameters that can be varied whilst preparing the video content for streaming over the network, only the packetisation scheme, frame rate of the video, and the size of the video frame is varied. The video frame size is the number of packets required to transmit a single video frame and relates to the bitrate of the video frame. The video frame sizes were varied from 3.1kB, 6.1kB and 9.2kB. The video was generated and streamed across the network using RTPTools [7]. Figure 2 shows how the frame rate was increased every 300sec and video frame sizes were varied every 100sec resulting in a bitrate that increases in an Additive Increase Proportional Decrease (AIPD) manner over time and reaches a maximum bitrate of 2.1Mbps after 1700sec. When streaming MPEG-4 files, each video and audio track must have its own associated hint track. Hint tracks are used to support streaming by a server and indicate how the server should packetise the data. The hint track setting indicates the MTU of the packets to be sent. Thus, a hint track MTU of 512B ensures that no packet for this stream will exceed 512B. In these experiments several different hint track MTU sizes were investigated. The video frame

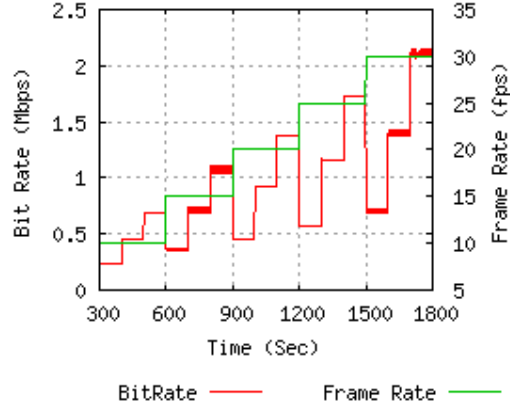

Fig.2. Video Stream Characteristics

sizes were chosen to reflect the mean number of packets per video frame when using a hint track MTU setting of 1024B and 512B. For example, when using a hint track MTU setting of 512B, the video frame sizes were in the set {6, 12, 18} packets per video frame and when using a hint track setting of 1024B, the video frame sizes were in the set {3, 6, 9} packets per video frame.

III RESULTS

There are many factors which affect the QoS of video streaming applications over WLAN networks. These include network heterogeneity, receiver heterogeneity, congestion, bandwidth fluctuations, delays, packet loss, retransmissions, noise and interference. For video streaming applications, packet loss and loss due to excessive delay are the primary factors that affect the received video quality. We compare the performance in terms of the received bitrate, mean packet delay, and loss rates for wired located and wirelessly located video streaming server.

a) Bit Rate Analysis

To achieve acceptable presentation quality, the transmission of a real-time video stream typically has minimum bandwidth requirement. In this section, the received bitrate at the client is analysed.

Table 1 summarises the results for the maximum received bitrate for a wired and wireless located video server and the number of concurrent video streams using a packetisation scheme of 512B and 1024B. It was found that when there is a single video stream, the client receives the maximum bitrate of 2.1Mbps from the video server located in the wired network regardless of the packetisation scheme used. However as the number of concurrent video streams is increased, the packetisation scheme reduces the received bitrate. When the number of concurrent video streams is increased to two and three streams,

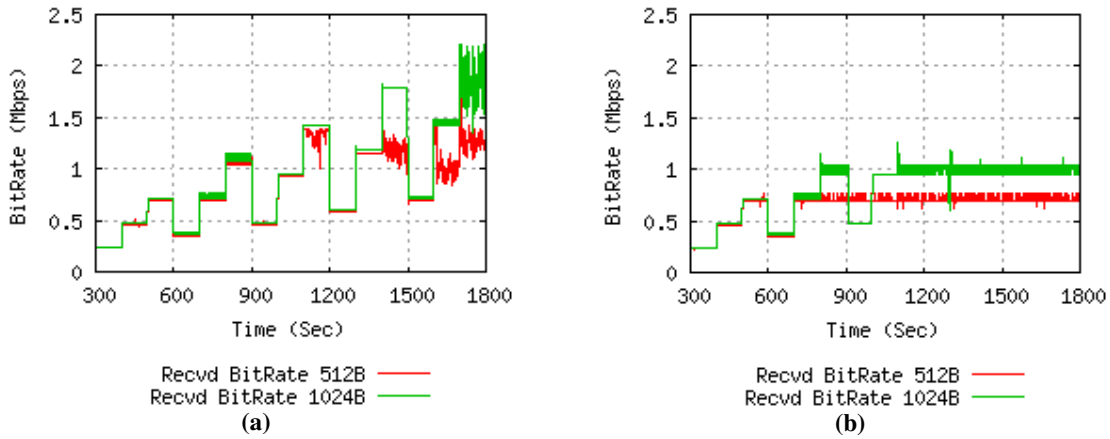

Fig.3 Received bitrate per client with three concurrent streams
 (a) for Wired located video server (b) Wireless located video server

Table 1: Comparison of Received Bit-Rate

	1 Video Client Maximum Received Bit Rate (Mbps)				2 Video Clients Maximum Received Bit Rate (Mbps)				3 Video Clients Maximum Received Bit Rate (Mbps)			
	512B		1024B		512B		1024B		512B		1024B	
	Per Client	Total Recvd Load	Per Client	Total Recvd Load	Per Client	Total Recvd Load	Per Client	Total Recvd Load	Per Client	Total Recvd Load	Per Client	Total Recvd Load
Wired Server	2.10	2.10	2.10	2.10	2.05	4.10	2.10	4.20	1.3	3.90	2.00	6.00
Wireless Server	2.10	2.10	2.10	2.10	1.10	2.20	1.50	3.00	0.75	2.25	1.00	3.00

the received bitrate by each client is reduced to 2.05Mbps and 1.3Mbps respectively when using a packetisation scheme of 512B. However, when using a packetisation scheme of 1024B, each client receives the maximum bitrate of 2.1Mbps and 2.0Mbps respectively. A similar trend is observed when using a wirelessly located video streaming server. When the server is using a packetisation scheme of 512B, the maximum received bit rate per client is reduced from 2.1Mbps to 1.1Mbps to just 0.75Mbps as the number of concurrent video streams is increased from one to three. Similarly, when using an MTU of 1024B, the maximum received bitrate per station is reduced from 2.1Mbps, to 1.5Mbps to 1Mbps.

Figure 3 shows the received bit rate for wired and wireless server with 3 concurrent streams. It can be seen that the WLAN becomes saturated when there are three concurrent streams. When using a wired server, the AP becomes saturated with a total throughput of 6Mbps and 3.9Mbps when using a packetisation scheme of 1024B and 512B. The wireless located server achieves a maximum throughput of 3Mbps using 1024B packetisation scheme and 2.25Mbps using 512B packetisation scheme.

The maximum received bitrate is less when using a smaller packetisation scheme. When using a

smaller packet size, more packets are required to transmit the same amount of video data. The AP must gain access to the medium to transmit each packet by deferring to a busy medium and decrementing its MAC back-off counter between packet transmissions [8]. For 512B packets the AP must gain access to the medium twice as often compared to 1024B packets which increases the likelihood of collisions and packets being dropped at the AP queue so the received bit rate was less when using 512B packets. However by using larger packets, the AP accesses the medium and transmits the data more efficiently.

As expected, the received bit-rate was always less when using a wireless located server than that achieved for wired server for multiple clients. When both the server and client are located on the same WLAN, the video stream occupies twice as much resources since the video is transmitted from the server to the AP and then from the AP to the video client. For example, it can be seen that when there are three concurrent streams using 1024B packetisation, the WLAN becomes saturated at 6Mbps using a wired server and 3Mbps using a wireless server. However given that the wireless server uses twice as many resources to transmit on the uplink to the AP and on the downlink to the client, the stream in fact occupies 6Mbps.

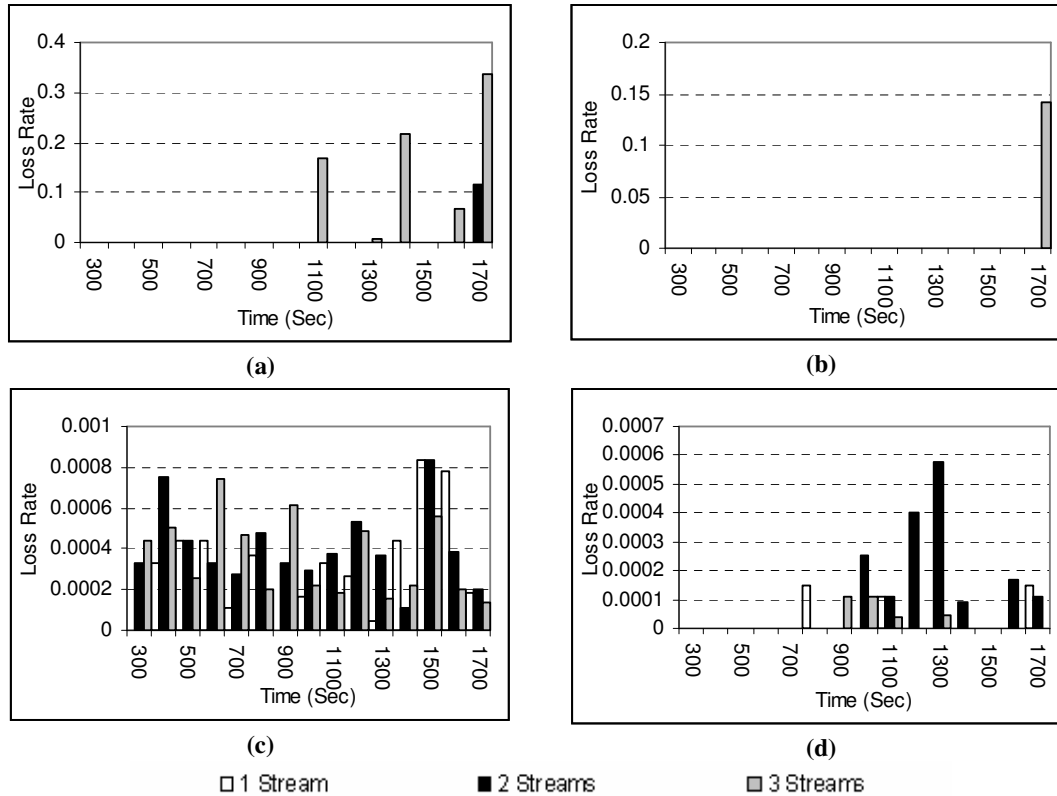

Fig.4 Loss-Rate for 3 concurrent video stream (a) Wired server using 512B packetisation scheme (b) Wired server using 1024B packetisation scheme (c) Wireless Server using 512B packetisation scheme (d) Wireless server using 1024B packetisation scheme

b) Loss Rate Analysis

For streamed multimedia applications, loss of packets can potentially make the presentation displeasing to the users, or in some cases make continuous playout impossible. Multimedia applications typically impose some packet loss requirements. Specifically, the packet loss ratio is required to be kept below a threshold to achieve acceptable visual quality. In particular, the packet loss ratio could be very high during network congestion causing severe degradation of multimedia quality. Even though WLAN networks allow for packet retransmissions, the retransmitted packet must arrive before its playout time. If the packet arrives too late for its playout time, the packet is useless and effectively lost. For video streaming applications, a video frame cannot be decoded at the client until all the packets for the video frame have been received. Lost packets and excessively delayed packets negatively affect the ability of the video decoder to decode the video frame and this reduces the received video quality.

In the experiments reported here, the bit rate of the video stream increases over time. As a consequence the loss rate of the video stream varies over time. Figures 4(a) and 4(b) show the loss rate variations

for a wired video server for one to three concurrent video streams using a packetisation scheme of 512B and 1024B. It can be seen that when there are three concurrent video streams, the loss rates reach 30% and 15% when the bitrate reaches a maximum for a packetisation scheme of 512B and 1024B. By using a packetisation scheme of 512B, twice as many packets are required to transmit the video frame. In this way, the transmission buffer at the AP becomes saturated more quickly resulting in packets being dropped.

In contrast when using a wireless video server, as shown in Figure 4(c) and 4(d), the loss rates remain at relatively low levels at less than 1% but are throughout the experiments. Loss in the WLAN medium occurs due to collisions and packet retransmissions. Packets are lost when they reach their retransmission limit. It can be seen that when using a smaller packet size, there is a higher loss rates and this is due to the increased number of packets that need to be transmitted. It can also be seen that the number of concurrent streams does not affect the observed loss rates.

c) Delay Analysis

Real-time multimedia is particularly sensitive to delay, as multimedia packets require a strict bounded end-to-end delay. That is, every multimedia packet

must arrive at the client before its playout time, with enough time to decode and display the contents of the packet. If the multimedia packet does not arrive on time, the playout process will pause, or the packet is effectively lost. In a WLAN network, in addition to the propagation delay over the air, there are additional sources of delay such as queuing delays in the AP, the time required by the AP to gain access to the medium and retransmissions on the radio link layer.

Packet loss and packets dropped due to excessive delay are the primary factors that have a negative effect on the received video quality. Real-time multimedia is sensitive to delay, as multimedia packets require a strict bounded end-to-end delay. Every multimedia packet must arrive at the client before its play out time, with enough time to decode and display the contents of the packet. If the multimedia packet does not arrive on time, the play out process will pause and the packet is effectively lost. In a WLAN network, in addition to the propagation delay over the air interface, there are additional sources of delay at the AP such as queuing delay plus the time required by the AP to gain access

to the medium and to successfully transmit the packet which may require a number of retransmission attempts. If the packet arrives too late for its play out time, the packet is useless and effectively lost. Multimedia packets delayed past their play out time are essentially wasting resources in the network.

Figure 5 shows how the mean network delay averaged every second varies over time for streaming the video clip MTU setting of 1024B and 512B respectively for one to three concurrent video streams. In the experiments reported here, the size of the video frame is increased every 100sec. Figure 5(a) shows the delay variations over time for a wireless video server using a packetisation scheme of 1024B for one to three concurrent video streams. It can be seen that as the number of video streams is increased, the mean delay is increased since there are more packets in the AP transmission buffer and so the packet must wait longer in order to be transmitted.

In addition, the mean delay is affected by the packetisation scheme used as can be seen by comparing Figure 5(a) and 5(b). This is expected since the smaller the packet size, the greater the

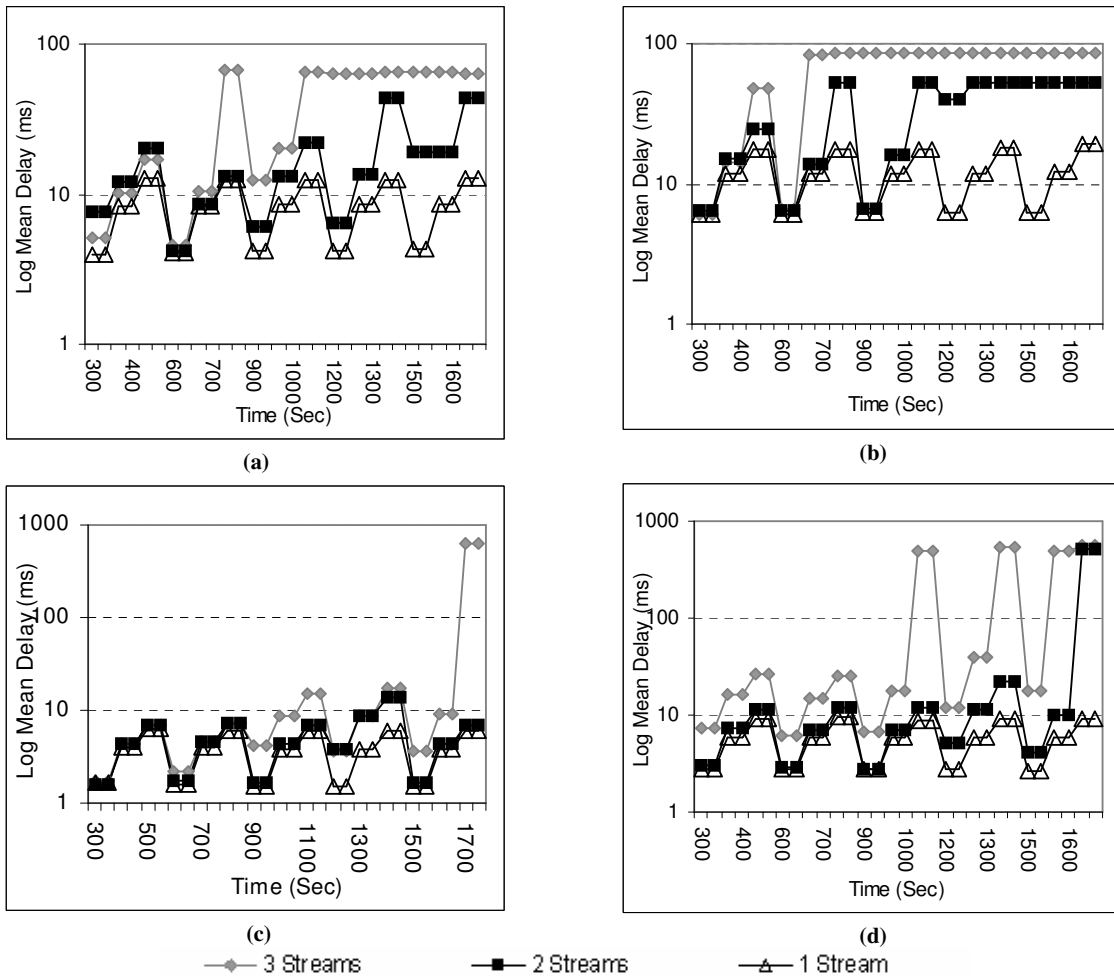

Fig 5 Mean delay for wired and wireless located video server (a) Wireless server using 1024B packetisation scheme (b) Wireless server using 512B packetisation scheme (c) Wired server using 1024B packetisation scheme (d) Wired server using

number of packets that are in the queue at the AP. With a greater number of packets in the queue, the video packets are more likely to be delayed longer since they must wait for the AP to gain access to the medium by deferring to a busy medium and decrementing its back-off counter for each of the packets in the queue ahead of it.

The mean delay is closely related to the size of the video frame. For example, if many packets are required to send the video frame, the AP must access the medium in order to transmit each packet and so each packet must wait longer in the AP transmission buffer causing it to experience increased delays. This can be seen by comparing the delay variations for three concurrent streams in Figures 5(a) and 5(b) with Figure 3(b) that shows the maximum received bitrate.

It can be seen that the mean delay when using a wireless server never exceeds 100ms. In contrast, the mean delay when using a wired server reaches a maximum of 636ms and 562ms when using a packetisation scheme of 1024B and 512B respectively.

IV CONCLUSIONS

In this paper, we compared the performance of wired and wireless video streaming for two different packetisation schemes in terms of bit rate, loss rate and packet delay. For video streaming applications, packet loss and packets dropped due to excessive delay are the primary factors that affect the received video quality.

Through experimentation we found that the received bitrate was much higher when using a wired server and large packetisation scheme. However, this can be traded off against an increased packet loss rate and increased delay when there are many concurrent streams. In contrast, the wireless server has a lower packet delay and loss rates.

It was found that the packetisation scheme has an important effect on all these parameters. By using small packets not only is there an increased header overhead due to the fact that more packets are required to send the same amount of data, but also more MAC layer ACKs need to be sent. In addition, by using small packets the AP must access the medium more often which results in packets incurring greater queuing delays. In addition, due to the increased queuing delays, it is more likely that the AP transmission buffer will become saturated which can result in packets being dropped under heavily loaded conditions.

Future work is planned out to investigate the impact of contention among different stations on the recently approved QoS enhanced IEEE 802.11e[8].

V ACKNOWLEDGEMENT

The support of the Science Foundation Ireland, grant 03/IN3/1396, under the National Development Plan is gratefully acknowledged.

References

-
- [1] N. Cranley, M. Davis, "Performance Analysis of Network-level QoS with Encoding Configurations for Unicast Video Streaming over IEEE 802.11 WLAN Networks", WirelessCom 2005, Maui, Hawaii, June 2005
 - [2] N. Cranley, M. Davis, "Performance Evaluation of Video Streaming with Background Traffic over IEEE 802.11 WLAN Networks", 1st ACM Workshop on Wireless Multimedia Networking and Performance Modelling (WMuNeP 2005), Montreal, Canada, October 2005
 - [3] Q. Zhang, W. Zhu, Y-Q. Zhang, "End-to-End QoS for Video Delivery Over Wireless Internet", in Proc. of the IEEE, Vol. 93, No. 1, January 2005
 - [4] WinDump, <http://windump.polito.it/>
 - [5] NetTime, <http://nettime.sourceforge.net/>
 - [6] S. B. Moon, P. Skelly, D. Towsley, "Estimation and Removal of Clock Skew from Network Delay Measurements", in Proc. of IEEE InfoComm'99, March 1999
 - [7] RTPTools, <http://www.cs.columbia.edu/IRT/software/rtptools/>
 - [8] LAN/MAN Committee of the IEEE Computer Society, "IEEE P802.11e/D11.0, October 2004, Part 11: Wireless Medium Access Control (MAC) and Physical Layer (PHY) specifications: Amendment 7: Medium Access Control (MAC) Quality of Service (QoS) Enhancements"