



2005-05-01

# Friction and Adhesion in Rigid Surface Indentation of Nitrile Rubber

Stephen Jerrams

Dublin Institute of Technology, [stephen.jerrams@dit.ie](mailto:stephen.jerrams@dit.ie)

Follow this and additional works at: <http://arrow.dit.ie/cerart>

 Part of the [Polymer and Organic Materials Commons](#)

## Recommended Citation

Jerrams, S. (2005) Friction and Adhesion in Rigid Surface Indentation of Nitrile Rubber. *Journal of Materials and Design*, Vol 26, Issue 3, May 2005, PP 251-258. DOI: 10.1016/j.matdes.2004.02.012

This Article is brought to you for free and open access by the Centre for Elastomer Research at ARROW@DIT. It has been accepted for inclusion in Articles by an authorized administrator of ARROW@DIT. For more information, please contact [yvonne.desmond@dit.ie](mailto:yvonne.desmond@dit.ie), [arrow.admin@dit.ie](mailto:arrow.admin@dit.ie).

Creative Commons License

This work is licensed under a Creative Commons Attribution-Noncommercial-Share Alike 3.0 License



## **Friction and adhesion in rigid surface indentation of nitrile rubber.**

**S J Jerrams\***

Dublin Institute of Technology (DIT)

Directorate of Research and Enterprise, Fitzwilliam House, 30 upper Pembroke Street,  
Dublin 2, Ireland

### **Abstract**

When a rigid body in the form of a plane strain indenter is forced into an elastomer, the asperities on the surface of the indenter are filled by the softer material. As depth of ingress increases, the rubber displaced into the indenter asperities exhibits stick-slip behaviour. The rubber adheres to the rigid body and if the depth of ingress is held at a maximum, the level of adhesion remains constant despite short-term load relaxation occurring in the rubber.

This text describes the influence of a range of factors on indentation forces and adhesion in rigid indentation of hydrogenated nitrile rubbers. Blocks of rubber in four hardness grades were subjected to plane strain indentation using mild steel plate indentors. The edges forced into the elastomers were radiused to produce ingress of a semi-circular profile into the blocks and this allowed subsequent finite element modelling of the indenter as a continuum. During physical testing, indentation rates and indenter surface finish were varied and load/displacement characteristics, adhesion and short-term load relaxation were measured. The correlation between indentation loads at the common maximum depth of ingress and the adhesion theory of friction for different surface finishes was examined. Nonlinear finite element stress analyses, employing adaptive meshing, alternative friction algorithms and competing strain energy density functions were used to model the indentation process and comparisons of surface profiles with test results are included.

**Key words:** Elastomer, Adhesion, Indentor, Friction

\* Telephone 00 353 (0)1 4027537, email stephen.jerrams@dit.ie

### **Symbols.**

$c$	Stress relaxation constant ( $s^{-1}$ )
$F$	Indentor force (N/mm of indentor width)
$F'$	Relaxed indentor force (N/mm of indentor width)
$R$	Feed rate (mm/s)
$t'$	Time (s)
$\alpha$	Indentor force constant ( $kg\ mm^{-1} \times 10^{-3}$ ) dependent on indentor surface finish
$\beta$	Indentor force constant ( $kg\ s^{-1} \times 10^{-3}$ ) dependent on indentor surface finish
$\delta$	Displacement (mm)
$\zeta$	Stress relaxation constant ( $s\ mm^{-1}$ )
$\psi$	Stress relaxation constant (no units)

## **1. Introduction**

Plane strain tests have been carried out to investigate load–displacement characteristics and load relaxation in nitrile rubbers. Additionally, friction and adhesion in the tests were investigated. Eqn 1 gives an empirical formula suggested by Jerrams *et al* [1], relating load and displacement for rigid indentation of nitrile and hydrogenated nitrile rubbers (NBR and HNBR respectively). The formula was derived from a series of tests on blocks of test grade rubber of 40, 50, 60 and 70 ‘Shore A’ hardness using 2 mm thick plate indentors with cylindrical radii on the indenting edge as shown in Figure 1. The 40 Shore A material was NBR, the others HNBR. The indentor edge configuration was chosen to avoid high local strains at ingress and provide a rigid surface as a continuum for subsequent finite element modelling. Three indentors were used in the tests, each having

a markedly different surface finishes produced by polishing, vapour blasting and shot blowing, but equivalent to polished, ground and machined surfaces respectively. Indentation rates were varied between 5 and 500 mm/min and the tests on HNBR were carried out dry and also with lubricant between the rubber and the indenter. Additionally, the short-term load relaxation characteristics of the materials were evaluated. Significantly, though the levels of adhesion between indenter and rubber and also the deformed surface of the rubber remained unchanged, loads beneath the indentors fell by as much as 60% in a ten minute period after ingress to full depth. Eqn 2 represents the relaxed indenter force in terms of initial feed rate and relaxation time.

$$F = (\alpha \ln R + \beta) \delta \quad (1)$$

$$F' = (\zeta \ln R + \psi) F_{\max} e^{-ct} \quad (2)$$

The principal conclusions in respect of load / displacement characteristics and load relaxation are summarised below.

- i) predictably, the harder the rubber the greater the indentation force.
- ii) As indentation feed rates increase, indentation loads increase. This indicates that for a higher feed rate there is less simultaneous stress relaxation and greater dynamic friction
- iii) Dry indentation produces greater loads than lubricated indentation. Indentation forces will be influenced by the shearing forces in the lubricant that are a function of the lubricant's viscosity. This situation is considered in section 2.2, where a distinction is made between adhesion mechanisms and deformation mechanisms in friction. [2]
- iv) Lubrication gives a smaller range of indentation loads with variation in feed rates than is seen in the dry tests
- v) The harder the rubber the greater the range of indentation force with variation in feed rate.
- vi) For each set of tests the polished indenter tended to give the lowest load. This trend is more pronounced in the tests using lubricant.

vii) For each set of tests the shot blast indenter tended to give the highest load. This is more pronounced in the tests using lubricants.

viii) The mean absolute errors from applying eqn 1 for 4 mm ingress are 3.2% (dry) and 2.1% (lubricated). This suggests that using the empirical plane strain formula can be used for benchmarking hyperelastic FEA.

ix) Load relaxation is pronounced in the first 30s of the relaxation period in all tests. After 600s it continues at a constant rate, common to all the tests. Hence relaxation curves are not converging.

x) Mean absolute errors for predicted relaxed loads, 600s after achieving full ingress depth, are 5.05% (dry) and 4.73% (lubricated). This error is too great to allow eqn 2 to be used for benchmarking viscoelastic elastomeric finite element analyses.

xi) Unsurprisingly, slower feed rates resulted in smaller stress relaxations than higher feed rates, i.e. more simultaneous stress relaxation took place in the tests with the slower feeds.

xii) Load relaxations in the tests using lubrication were less than in the dry tests. Again this is unsurprising, since lower loads in the tests using grease mean that there is bound to be a proportionately smaller relaxation.

xii) The harder rubbers experienced more load relaxation than the softer rubbers

iv) Indenter surface finish has no discernible effect on load relaxation.

All the tests were recorded using a video microscope and consequently levels of adhesion between samples and indentors were analysed. This text considers friction and adhesion for these plane strain rigid indentation tests.

## **2. Theoretical consideration of rubber/rigid body friction**

“...friction is sensitive to just about everything including breathing on the test-piece and any single point measurement is of limited use.” [3]

Perhaps the most comprehensive discussion and overview of static and kinetic friction is that presented by Martins *et al* [4]. They point out that although the governing parameters

for friction may be readily agreed on (bulk, surface layer materials, roughness, stress levels, sliding speed, temperature, environment, properties of lubricant and lubricant conditions), reproducibility of friction data with different experimental apparatus under otherwise similar conditions remains hard to achieve. The dynamic properties of test equipment influence results and it is with this knowledge that previous interpretations should be re-examined. The assumption that static friction is dependent on the time of stationary contact is inapplicable to the indenter tests considered here. Similarly, the dependence of kinetic friction on sliding speeds would appear to have little relevance, since relative sliding velocities between indenter and rubber are small and below that where kinetic friction reaches a maximum and thereafter decreases as material softens with increased temperature due to contact [5,6]. Increased indenter forces with higher feed rates largely reflect the differences in stress relaxation in the tests and the amount of kinetic friction cannot be determined. Bowden *et al* [7,8] first commented on the stick-slip motion associated with solid bodies sliding together. It was soon accepted that the motion they described was not only influenced by the nature of the surfaces in contact, but also by the dynamic properties; stiffness, inertia and damping, of the experimental apparatus used. The slip phase of the process could be associated with a fall in force normal to the surfaces in contact. This is as a result of high frequency normal oscillations of a sliding body. Normal vibrations are highly asymmetric due to the contact, stiffness and mass of the slider. Asperities on the slider and body increase the components of normal force as they collide. During each cycle of normal oscillation a slider will alternatively stick and slide. As the frequency is high, the amplitude small and the average sliding velocity small, the body will appear to be smooth sliding. Kinetic friction is thus seen to be lower than static friction at low speeds. At higher speeds, successive stick-slip cycles are smaller and the apparent coefficient of friction will increase with increase in slider velocity, up to a point where one of the materials in contact begins to soften [9].

It is reasonable to suggest that in rubber to metal contact problems, the much greater softness of the rubber means this situation is replicated and stick-slip cycles are comparatively large. An explanation of normal contact oscillations was given by Tolstoi *et al* [10]. They state that an increase in speed of the sliding body during contact,

increases upward components of the impulses exerted on the body asperities as they collide with the mating surface, increasing amplitudes of normal vibrations of the slider, which are governed by its stiffness and mass. Due to the nonlinearity of the normal force-penetration relationship, these vibrations are highly asymmetric. As a consequence of the increased amplitudes, the mean level of penetration decreases, so contact and thus friction force also decreases.

## **2.1 Theories of friction and the plane strain tests**

In the latter part of this century we have moved away from a belief in the roughness hypothesis; that friction is due to the interlocking of asperities and consequently friction force is proportional to load and unrelated to contact area. However, an adhesion hypothesis; that friction is due to adhesion between contacting surfaces founded when apparent areas of contact were considered. The adhesion hypothesis is alternatively called the 'the adhesion-shearing theory' that states that frictional resistance is equivalent to the force needed to break the true contact area in shear. Subsequently it has been shown that there is a significant difference between apparent and real area of contact and that the real contact is an important factor for determining the magnitude of friction. Finding this real contact area is problematic, though as normal contact forces increase surface deformation, or as a softer material assumes the profile of a harder contacting material, the actual contact area tends to the apparent contact area. This of course characterises rigid contact with rubber [11]. Even with an acceptance that friction is related to contact area it remains a complex phenomenon, governed by the surface interaction properties of the materials. These surface interaction properties are many and diverse but can be considered in two categories:-

- i) Volume properties – Yield strength, penetration hardness, stored elastic energy, thermal properties etc.
- ii) Surface properties – Chemical reactivity, surface energy, compatibility of contacting forces etc.

The friction force to start sliding is usually greater than the force needed to maintain sliding and this requires that friction coefficients have both static and kinetic values.

Values of kinetic friction were found to increase with sliding velocities above about  $10^{-2}$  mm/s for diverse, dry and lubricated surfaces [12,13]. Accordingly indentation force could be expected to increase with feed rate. However indentation force will increase with feed rate in tests on rubber due to differing rates of stress relaxation, so the contribution made by friction is not apparent. Also, Martins *et al* point out that even tests using the same materials and the same experimental apparatus at different feed rates produce friction-velocity plots that are not an intrinsic property of the surfaces in contact, but are more affected by the dynamic variables in the experiment [14]. The Instron 8501 Dynamic Testing System, used in the plane strain tests is an appropriate apparatus for determining load/displacement relations for static or dynamic applications. Clearly the dynamic properties of the machine and associated set-up make it inappropriate for a detailed investigation of the friction occurring in rubber/metal contact and controlled tests need to be devised to establish the contribution that friction makes. Perhaps tests similar to those carried out by Hegmon [15] on natural and butyl rubbers and samples prepared from solid tyres would permit an improved understanding of friction due to rigid indentation of the nitrile rubbers. He separated the influence of surface (or adhesive) friction from bulk (or deformation) friction by conducting tests using a rotating rubber track and a stationary polished aluminium slider. The influence of surface friction at low speeds could not be eliminated with lubrication. A solution was found by coating the rubber with Teflon tape and vibrating the tape with a shaker, which effectively eliminated all surface friction. Hegmon found that bulk friction increased linearly with increase in pressure whilst surface friction, which was the larger of the two, remained approximately constant.

It is not considered feasible to make definitive statements about the influence of varying different parameters in the tests. If a comparison of dry and lubricated indentation forces is made, it is possible to determine which parameters have the greatest influence on the contribution friction makes to the total force. Table 1 compares the mean differences between loads on the basis of rubber hardness, indenter surface finish and indentation feed rate. The hardness of the rubber and hence its internal structure is the predominant



determinant of surface friction in rubber/rigid body contact. Surface finish and indentation feed rates appear to have no marked effect on the level of friction.

### **2.1.1 Correlation between indenter forces and the adhesion theory of friction**

Relating levels of friction between solids to contact area, superficially suggests that friction force is independent of surface roughness, but this is an over simplification. Experiments have shown [16] that over a wide range of surface finishes there is greater friction at the extremes; where smooth surfaces insure that contact area is greatly increased and where interlocking of asperities result when rough surfaces contact. A large range of surface finishes between these two conditions produces approximately constant friction. This situation is shown in figure 2 and the maximum indenter forces plotted against indenter surface finishes from the dry tests are shown in figure 3.

From figure 2 it can be observed that the three indenter surface finishes are in the three areas that categorise the adhesion hypothesis. The tests on the 40 Shore A NBR rubbers appeared to correlate to the theory in that all but one of the feed rates used gave a concave curve consistent with figure 2 (reference figure 3). However only seven of the fifteen curves for the harder compounds complied with the adhesion hypothesis. As the contribution that friction resulting from contact makes to the total indentation force is not known, it is not possible to state if the adhesion hypothesis applies. Neither can it be said if the surface finish of the rigid body has any significant influence on the contact force.

## **2.2 Adhesion in polymeric materials**

The observed adhesion occurring between plane strain indentors and nitrile rubbers, has significant bearing on the sealing capabilities of elastomers and the surface profiles of rubber components in the vicinity of rigid contact. The relationship between friction and adhesion for polymers or when a polymer slides over a rigid substrate is described by Cherry [2]. There are two phenomena that give rise to friction; an adhesion mechanism and a deformation mechanism. The difference between them is at times nebulous, but the

adhesion mechanism arises from the rupture of intermolecular bonds, whilst the deformation mechanism results from the mechanical interaction of the two surfaces. A distinction can be made between the two by considering two situations:-

- i) two perfectly smooth surfaces in contact, where the force needed to initiate sliding is solely adhesive
- ii) where a good lubricant is present preventing the formation of interfacial bonds, so that only a deformation mechanism is present.

The values given in table 1 appear to indicate that the contribution made by an adhesion mechanism to indentation forces is approximately constant, i.e. the mean differences between dry and lubricated forces are similar for variation in feed rates and surface finishes.

Research of polymer adhesion has centred largely on a study of adhesion between polymers and not adhesion between polymers and metals. Adhesion is an interfacial process mainly dependent on the spreading of one material on the surface of another. Commercial rubbers are composites having internal properties determined by the adhesive interaction between the rubber matrix and the carbon filler. The adhesion observed in the plane strain tests can be attributed primarily to the properties of the rubber. Hence it is reasonable to consider theories proposed for adhesion between polymers.

Vakula and Pritkyn [17] list eight competing theories for describing polymeric adhesion and quote Balzac who considered the piling up of facts as helplessness. They assume that "...a variety of sometimes mutually incompatible concepts appear to be obvious evidence of the lack of a unified physically non-contradictory theory". Consequently they contend that two approaches are capable of providing theoretical interpretations that address different aspects of the problem whilst supplementing each other. They are:-

- i) the thermodynamic approach

ii) the molecular-kinetic approach

The thermodynamic approach suggests there is a major difference between a molecule in the bulk of the elastomer and one at an interface with another body. It is argued that three forces impose their effect on a molecule at the interface, whilst at least four forces affect a molecule within the bulk [18]. Quantitatively this difference is expressed in terms of energy. Kinetic energy at the surface, derived from thermal agitation in rubber chain molecules will be greater than in the body of the material. An excess force per unit length on the surface is termed surface tension [19]. This tension is related to surface energy as a result of small thermodynamic changes in the surface region.

The molecular-kinetic approach suggests there are boundary layers at polymer surfaces where there is less tight bonding of the molecules. Thus a polymer is less dense and viscous at its surface [20]. To substantiate that more loose packing of molecules in boundary layers existed, Lipatov [21] used ultrasonic techniques that established entropy decreases in polymer boundary layers. In consequence, the boundary layer of a polymer in contact with a solid body is adsorptive. Moving away from this boundary layer this adsorption diminishes.

### **2.2.1 Adhesion between plane strain indentors and nitrile rubbers**

Adhesion in the indenter tests was measured to a reasonable accuracy by taking traces from the video recordings obtained. Screen scales were in a range between 72.5:1 and 45:1. As the indenter width is known, reasonably precise measurements were possible. A typical indenter image is shown in figure 4. The adhesion data is summarised in tables 2 to 4 and figure 5. Table 2 gives the range and mean values of adhesion for each compound. Table 3 gives ranges and mean values for changes in feed rate whilst table 4 shows the influence of indenter surface finish.

The level of adhesion is uninfluenced by the hardness of the compound. This is consistent with obtaining similar surface profiles for a range of hardness grades from the

physical tests. It is reasonable to suppose that the adhesion height, and hence the point at which the two surfaces separate, controls the surface profile in the indenter vicinity. Adhesion diminishes with feed rate and this reduction appears to be pronounced between indentation rates of 1 and 2 mm/s. If indentation rate 'R' (figure 5) is plotted as 'ln R', the curve retains a similar shape. If a linear trend-line is fitted to a plot of indentation rates averaged for hardness and surface finish against 'ln R' (figure 6) then a representative reduction in adhesion with feed rate is observed. It is impractical to predict a trend from tests using only three indenter surface finishes (table 4), but it is evident that the coarsest indenter gives rise to less adhesion. This is consistent with point ii) at the start of section 2.2. Good surface finishes adhere more than poor surface finishes. Figures 7 and 8 show localised surface deformations for all feed rates at two extreme cases where:-

- i) the softest rubber and finest surface finish are combined (40 Shore A and polished indenter) and
- ii) the hardest rubber and coarsest indenter are combined (70 Shore A and shot blown indenter)

Similar behaviour was observed in all tests. The surface profiles generated by finite element analyses are added to the plots. It is evident that the finite element analysis does not model surface deformations effectively, modelling too little surface adhesion between the two materials.

The surface profiles in all tests did not alter with load relaxation, despite the load reduction over 10 min being 50% or greater in some tests. The surface profile away from the indenter appears to be controlled by the amount of adhesion between indenter and rubber. This situation is compatible with the findings of Johannknecht, [22] that indentations, either punch or plane strain, produce consistent surface profiles despite viscoelastic behaviour. A cursory inspection of the tests using lubricant show far less adhesion and this is consistent with point i) at the start of section 2.2.

### **3 Conclusions**

Adhesion levels occurring during indentation of nitrile rubbers are not influenced by the hardness of the compound. Increases in feed rate lead to lower levels of adhesion in plane strain indentation. Coarse rigid surfaces produce less adhesion than smooth ones and this is consistent with the findings of Cherry [2] discussed in section 2.2. Adhesion levels are less in all tests using a lubricant.

The level of adhesion between indenter and filled rubber, created during contact, does not diminish with stress relaxation if the depth of contact is maintained. Hence the adhesion appears to be strain controlled and coefficients of friction in excess of unity, giving rise to large tangential forces between contacting surfaces, ensure that the state of equilibrium in the region of contact is unaltered. Similarly the surface profile outside the vicinity of indentation is governed by the level of adhesion and does not change with time. If the constancy of adhesion level and surface deformation is considered in conjunction with Johannknecht's findings for axisymmetric cyclic loading of nitrile rubbers, it becomes evident that viscoelasticity is a stress controlled phenomena, whilst strains at given indentations replicate with time and repeated loading. This suggests that a simplified material model for rubber components could be derived which comprises a deformation term and a time dependent term.

The plane strain tests were primarily concerned with load/displacement relations and load relaxation. Consequently, a detailed analysis of friction between rubber and indenter proved not to be feasible. Indications from the initial NBR tests, that results for load/displacement might broadly conform to the adhesion theory of friction, were not borne out by the subsequent HNBR tests. However, since the largest part of the force measured in each test results from the internal structure of the compound, it is unsurprising that other influences are difficult to quantify and the adhesion theory is

neither proven nor unproven. If the asperities on the rigid indenter surfaces are filled by the rubber, it is reasonable to expect real contact areas to be similar for all the tests. More work would be done in shearing asperities for the coarser surface finishes, producing increases in indenter force with greater surface roughness and this, in fact, is the case [1].

### **3.1 The influence of lubrication in plane strain indentation**

In the plane strain indentation and stress relaxation tests, lubrication reduced loads and load ranges. The Load relaxation was less in the tests using lubricant, but this is to be expected since load levels were less in these tests. Adhesion is less in the tests using lubricant. The similarity of changes in indenter force reduction, for different feed rates and surface finishes when a lubricant is used, suggests that the contribution of the adhesion mechanism to total indenter force is constant for a particular compound.

#### **3.2.1 Obtaining reliable friction data for rubber/rigid indentation**

It is problematic to attempt to study the influence of friction in plane strain indentation, without devising specific tests. It is essential to minimise the influence of the dynamic properties of apparatus if friction data is to be believed. Tests also need to quantify the contributions of bulk friction and adhesive friction. Thus a test programme is required that develops the ideas of Hegmon [15] by using a surface coating and shaker mechanism to eliminate adhesive friction from some of the tests.

### **References**

- [1] Jerrams S.J., Kaya M and K.F. Soon “The effects of strain rate and hardness on the material constants of nitrile rubbers” *The Journal of Materials and Design*, Vol 19 No 4, August (1998)
- [2] Cherry B.W. “Polymer Surfaces” pp95-138 Cambridge University Press (1981)
- [3] Brown R.P. “Physical Testing of Rubber”, 2nd Ed., p185 Elsevier (1986)

- [4] Martins J.A.C., Oden J.T. and Simões F.M.F. “A study of static and kinetic friction” *International Journal of Engineering Science* Vol 28, No. 1 pp 29-92 (1990)
- [5] Kragelskii I.V. “Friction and Wear” Butterworths, (1961)
- [6] Kragelskii I.V., Dobychin M.N. and Kombalov V.S. “Friction and Wear: Calculation Methods” Pergamon Press (1982)
- [7] Bowden F.P. and Leben L. “The nature of sliding and the analysis of friction” *Proceedings of the Royal Society A169*, pp 371-391 (1939)
- [8] Bowden F.P. and Tabor D. “The area of contact between stationary and between moving surfaces” *Proceedings of the Royal Society A169*, pp 371-391 (1939)
- [9] Tolstoi D.M. “Significance of the normal degree of freedom and natural normal vibrations in contact friction”. *Wear* 10 pp 199-213 (1967)
- [10] Tolstoi D.M., Borisova G.A. and Grigorova S.R. “Role of intrinsic contact oscillations in normal direction during friction”. *Nature of friction of solids*, p 116, Nauka i Tekhnika, Minsk (1971)
- [11] Rabinowicz “E. Friction and Wear of Materials” 2nd Ed., p47, John Wiley (1995)
- [12] Rabinowicz E. “Friction and Wear of Materials” 2nd Ed., John Wiley (1995)
- [13] Bell R. and Burdekin M. “A study of the stick-slip motion of machine tool feed drives” *Proc. Institute of Mechanical Engineers* 184 (1) pp 537-557 (1969-70)
- [14] Martins J.A.C., Oden J.T. and Simões F.M.F. “A study of static and kinetic friction” *International Journal of Engineering Science* Vol 28, No. 1 p35, (1990)
- [15] Hegmon R.R. “The contribution of deformation losses to rubber friction” *Rubber Chemistry and Technology* Vol 42, 4, pp 1122-1135 (1969)
- [16] Rabinowicz E. “Friction and Wear of Materials” 2nd Ed., pp73-74, John Wiley (1995)
- [17] Vakula V.L. and Pritkyn L.M. “Polymer Adhesion. Basic physico- chemical principles” p10, Ellis and Horwood (1991)
- [18] Vakula V.L. and Pritkyn L.M. “Polymer Adhesion. Basic physico-chemical principles” p27, Ellis and Horwood (1991)

- [19] Cherry B.W. "Polymer Surfaces" p2 Cambridge University Press (1981)
- [20] Vakula V.L. and Pritkyn L.M. "Polymer Adhesion. Basic physico-chemical principles" p149, Ellis and Horwood (1991)
- [21] Tsarev P.K. and Lipatov Yu. S. "USSR High polymers" 17A, 717 (1975)
- [22] Johannknecht R. "The physical testing and modelling of hyperelastic materials for finite element analysis" PhD thesis, School of Engineering, Coventry University, 1999.

List of Figures and Tables.

- Figure 1 'Plane strain' indentation of rubber with cylindrical indenter
- Figure 2 Friction for varying surface finishes
- Figure 3 Indentation loads for all tests plotted against indenter surface finish
- Figure 4 Rubber/rigid surface adhesion from physical tests
- Figure 5 The variation of adhesion with indentation rate
- Figure 6. Adhesion trend over mean hardness and surface roughness values
- Figure 7 A comparison of surface deformations achieved in tests and FEA (40 Shore A)
- Figure 8 A comparison of surface deformations achieved in tests and FEA (70 Shore A)
  
- Table 1 A comparison of 'dry' and 'lubricated' test loads
- Table 2 Variation of plane strain adhesion with rubber hardness
- Table 3 Variation of plane strain adhesion with indenter feed rate
- Table 4 Variation of plane strain adhesion with indenter surface finish



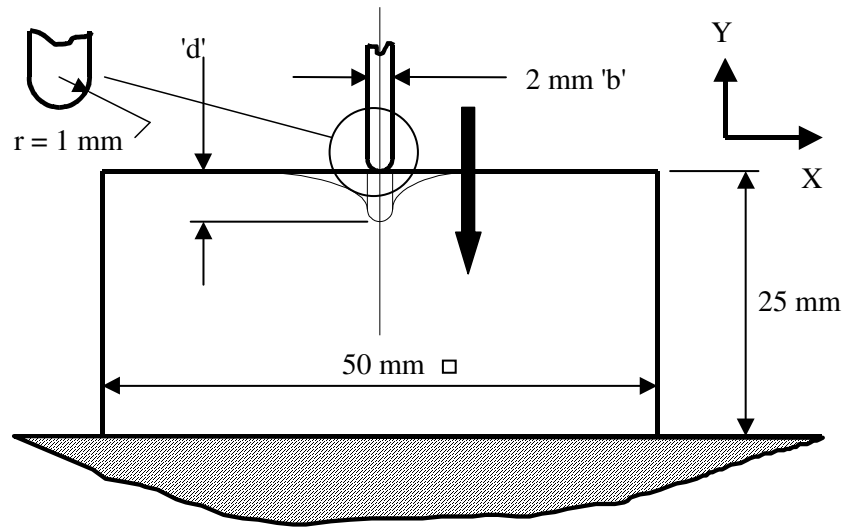

Not to scale

Figure 1 'Plane strain' indentation of rubber with cylindrical indenter

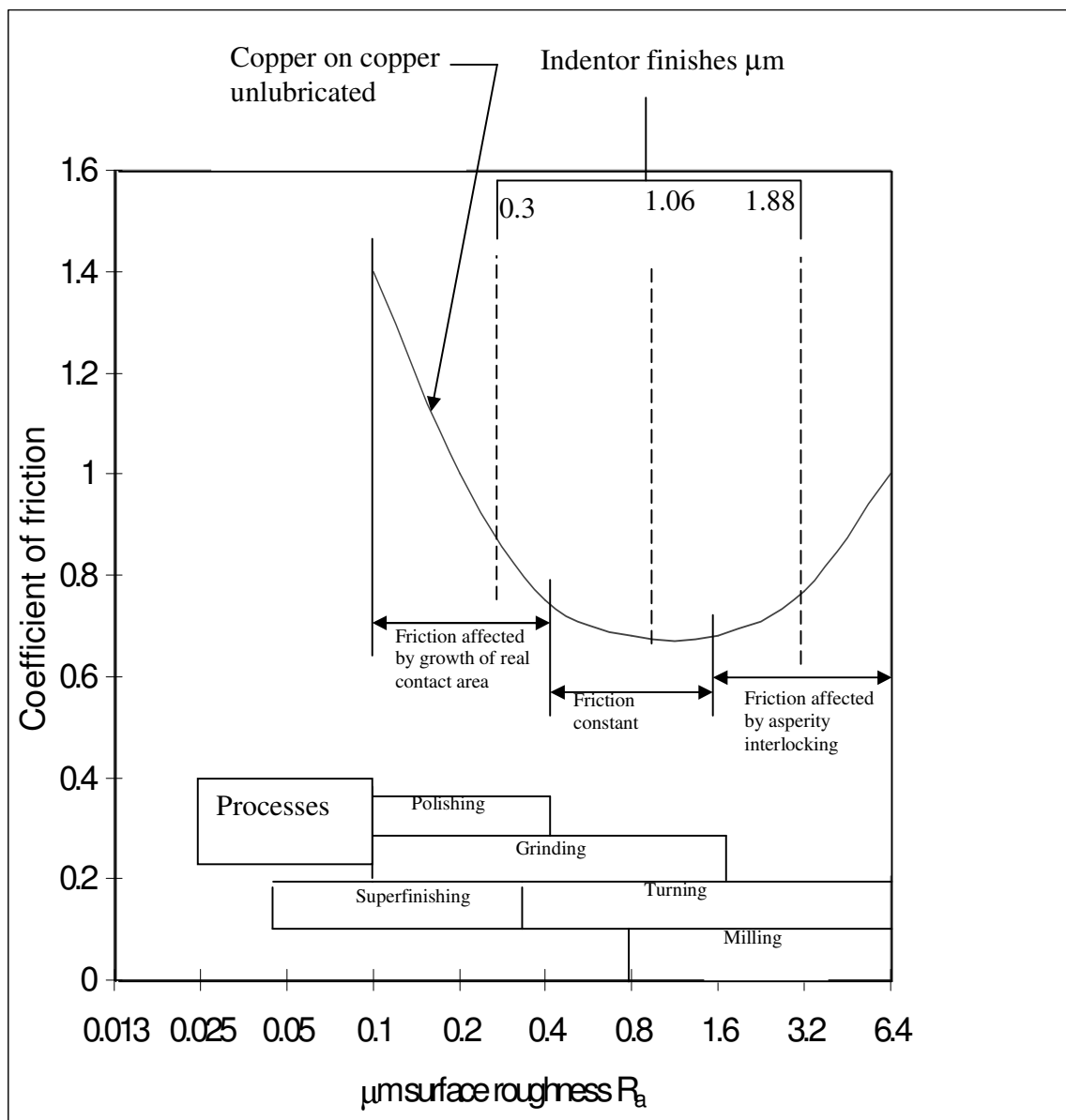

Figure 2 Friction for varying surface finishes

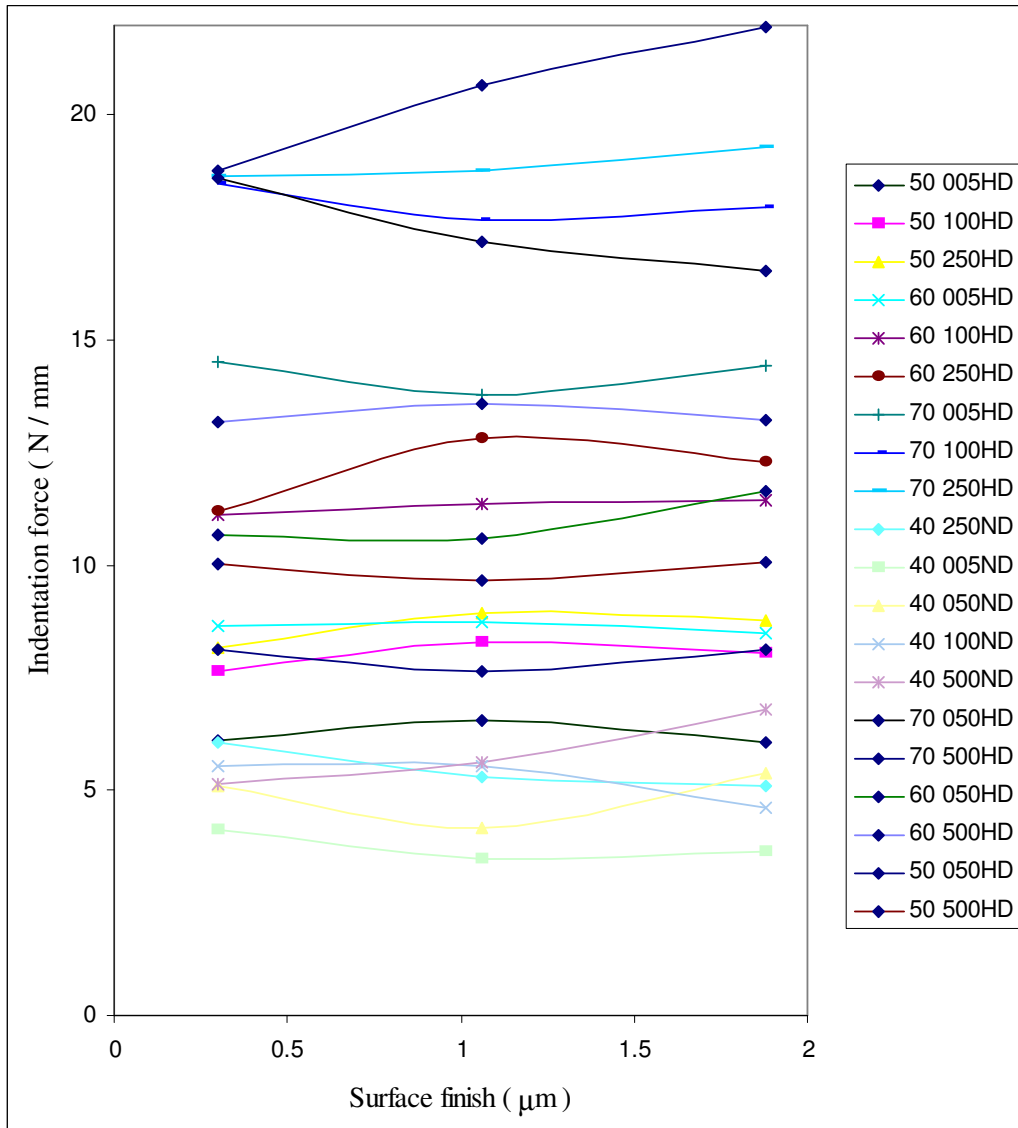

Figure 3 Indentation loads for all tests plotted against indenter surface finish

Hardness (Shore A)	Mean difference between dry and lubricated indentation loads (N/mm)
50	0.69
60	1.12
70	2.02
Surface finish ( $\mu\text{m}$ )	
0.3	1.17
1.06	1.32
1.88	1.05
Feed rate (mm/min)	
5	1.58
50	1.55
100	1.24
250	0.96
500	1.61

Table 1 A comparison of 'dry' and 'lubricated' test loads

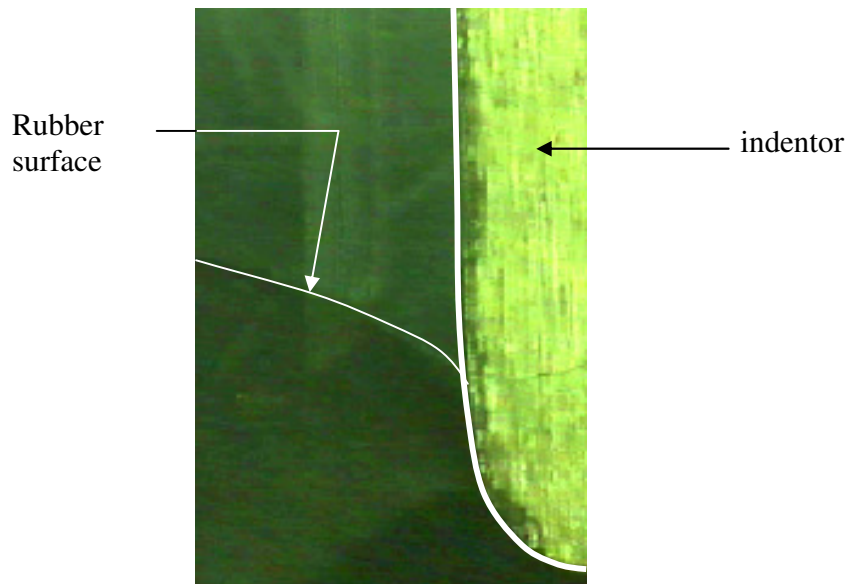

Figure 4 Rubber/rigid surface adhesion from physical tests

**Adhesion measured from indenter tip (mm)**

**Shore A hardness**

	<b>40</b>	<b>50</b>	<b>60</b>	<b>70</b>
<b>Mean</b>	1.58	1.48	1.58	1.51
<b>Max</b>	1.82	1.91	1.89	1.93
<b>Min</b>	1.35	1.27	1.31	1.27

Table 2 Variation of plane strain adhesion with rubber hardness

Feed rates in mm/min

	<b>5</b>	<b>50</b>	<b>100</b>	<b>250</b>	<b>500</b>
<b>Mean adhesion (mm)</b>	1.652	1.638	1.477	1.443	1.468
<b>Max adhesion (mm)</b>	1.82	1.909	1.712	1.708	1.81
<b>Min adhesion (mm)</b>	1.56	1.4	1.27	1.317	1.314

Table 3 Variation of plane strain adhesion with indenter feed rate

	<u>Surface finish (<math>\mu\text{m}</math>)</u>		
	<b>0.3</b>	<b>1.06</b>	<b>1.88</b>
<b>Mean adhesion (mm)</b>	1.564	1.577	1.491
<b>Max adhesion (mm)</b>	1.909	1.933	1.712
<b>Min adhesion (mm)</b>	1.35	1.267	1.314

Table 4 Variation of plane strain adhesion with indenter surface finish

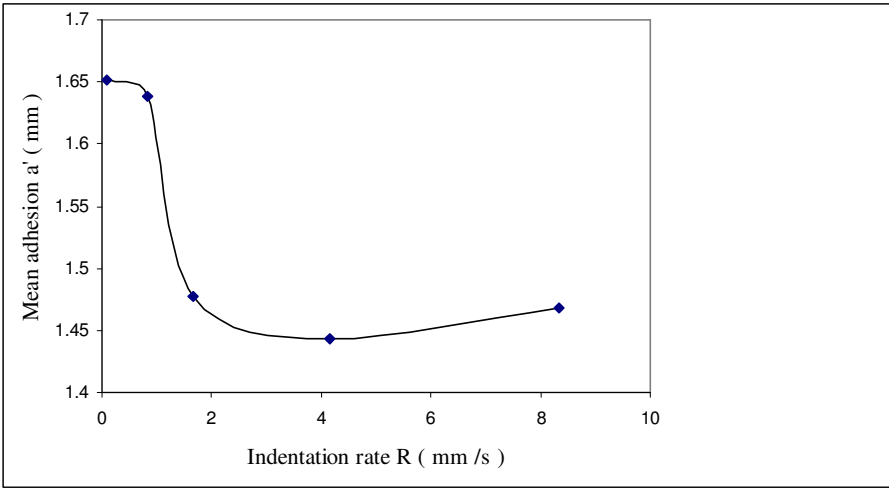

Figure 5 The variation of adhesion with indentation rate

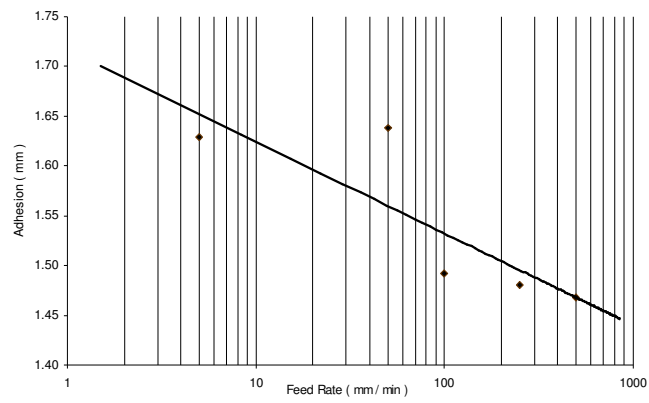

Figure 6. Adhesion trend over mean hardness and surface roughness values

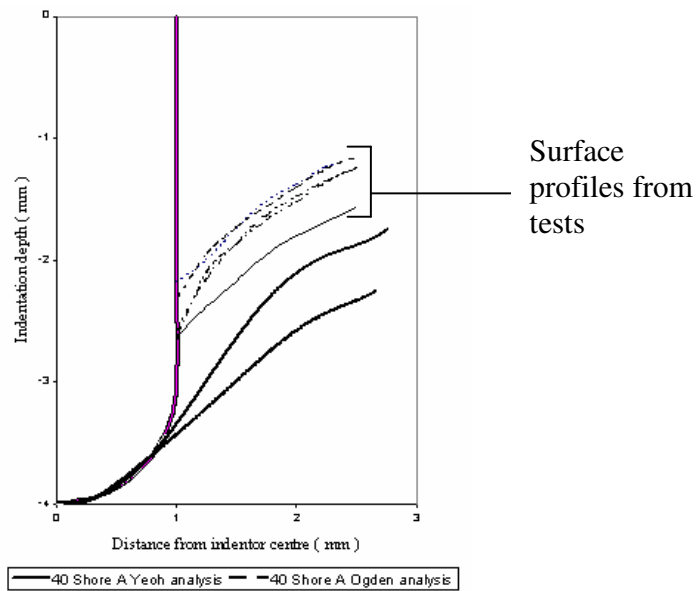

Figure 7 A comparison of surface deformations achieved in tests and FEA (40 Shore A)

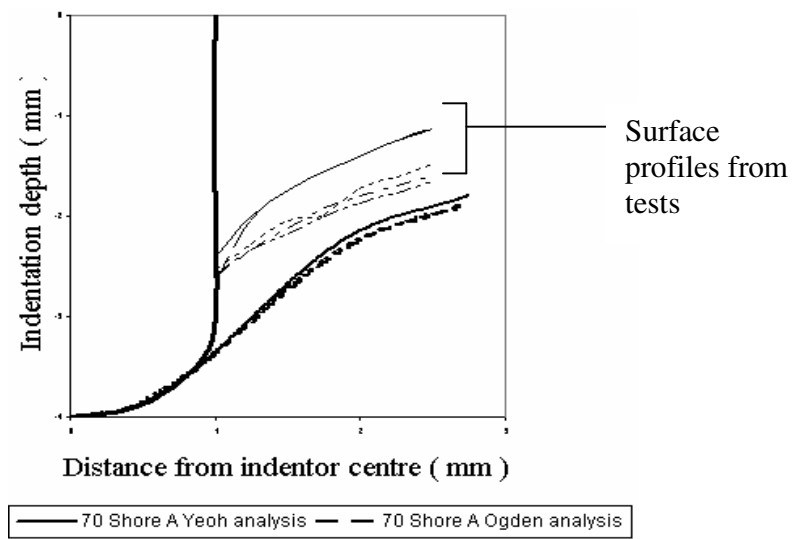

Figure 8 A comparison of surface deformations achieved in tests and FEA (70 Shore A)